

D6N

Track-Type Tractor



Engine

Engine Model	Cat® C6.6 ACERT™	
Emissions	U.S. Tier 4 Interim/EU Stage IIIB	
Gross Power – SAE J1995	132 kW	177 hp
Engine Power – ISO 14396	129 kW	173 hp
Engine Power – ISO 14396 (DIN)		175.3 hp
Net Power – SAE J1349	110.4 kW	148 hp

Engine (continued)

Net Power – ISO 9249	112 kW	150 hp
Net Power – ISO 9249 (DIN)		152 hp
Net Power – EU 80/1269/EEC	112 kW	150 hp

Weights

Operating Weight – XL	16 507 kg	36,392 lb
Operating Weight – LGP	18 096 kg	39,895 lb

D6N Features

Powerful Productivity

Standard electro-hydraulic controls help improve precision and response. Dedicated hydraulics, differential steering and machine control systems aid overall productivity. Features like the Eco Modes and Auto Engine Speed Control help reduce overall fuel use.

Operator Station

Ease of operation, cab comfort and layout help keep operators focused and more productive.

Engine and Emissions Technology

Cat engine and aftertreatment solutions meet EPA/ARB U.S. Tier 4 Interim, EU Stage IIIB and MLIT (Step 4) emission standards.

Integrated Technologies

AccuGrade™ Ready Option feature means easy installation of the performance enhancing Cat AccuGrade™ system. Cat Product Link helps maximize utilization and control costs.

Serviceability and Customer Support

Ease of service, Cat dealer expertise and machine rebuild capability help to reduce overall owning and operating costs.



Contents

Operator Station.....	3
Engine	3
Emissions Technology.....	4
Powertrain.....	5
Implement and Steering Controls	6
Integrated Technologies.....	7
Cooling System.....	8
Undercarriage	9
Work Tools.....	10
Rear Implements	11
Sustainability	12
Value Packages.....	13
Serviceability and Customer Support.....	14
Specifications.....	15
Standard Equipment.....	19
Optional Equipment.....	20
Notes.....	21

The D6N has earned reputation of being the machine that can be trusted to perform. It keeps material moving with the reliability, durability and comfort you expect from Cat® machines. It is engineered to excel on the most demanding worksites and in every job – from production dozing to fine grading.

The new D6N not only combines this proven reliability with technologies reducing emissions. It further improves fuel efficiency and productivity, all the more when equipped with the latest technologies for which it is an excellent platform.

Today's D6N is the best choice for customers in need of a versatile, easily transportable machine to do the job and help them meet their business objectives at a lower cost.

Operator Station

Designed for comfort, safety and high productivity



An isolation-mounted pressurized cab reduces dust entry, noise and vibration. Large glass panels provide excellent visibility. Intermittent wipers maximize visibility in poor weather conditions. Heating and air conditioning controls are conveniently located. Temperature control is automatic.

Updated dash and instrumentation streamline the display in a format that is more common across the Cat tractor line and keep the operator aware of any important information in his own language. Brightness and contrasts can be adjusted.

Fully adjustable, the air suspended seat includes bolsters to restrain side-to-side movement and steep slope footpads ensure a comfortable position when working on slopes.

The cab is pre-wired for a radio and includes two speakers, an antenna and a radio mount. A 10-Amp, 12-volt power converter provides supplemental power for cellular phones or two way radios. The cab also features convenient storage compartments, a cup and coat holder.

Engine

Power and reliability

The D6N features a Cat C6.6 ACERT™ engine and a Cat Clean Emission Module to deliver the performance that customers demand, while meeting U.S. Tier 4 Interim, EU Stage IIIB and Japan MLIT Step 4 emission standards.

The Cat C6.6 is an in-line configured engine. The ACERT Technology features advanced electronic control, precision fuel delivery, refined air management and aftertreatment technologies. The system is optimized based on engine size, the type of application and the geographic location in which it will work. To assure that our Tier 4 Interim technology will meet our customers expectations for reliable trouble-free service, we subjected these products to over one million operating hours of test and validation before sale of the first Tier 4 Interim machine.

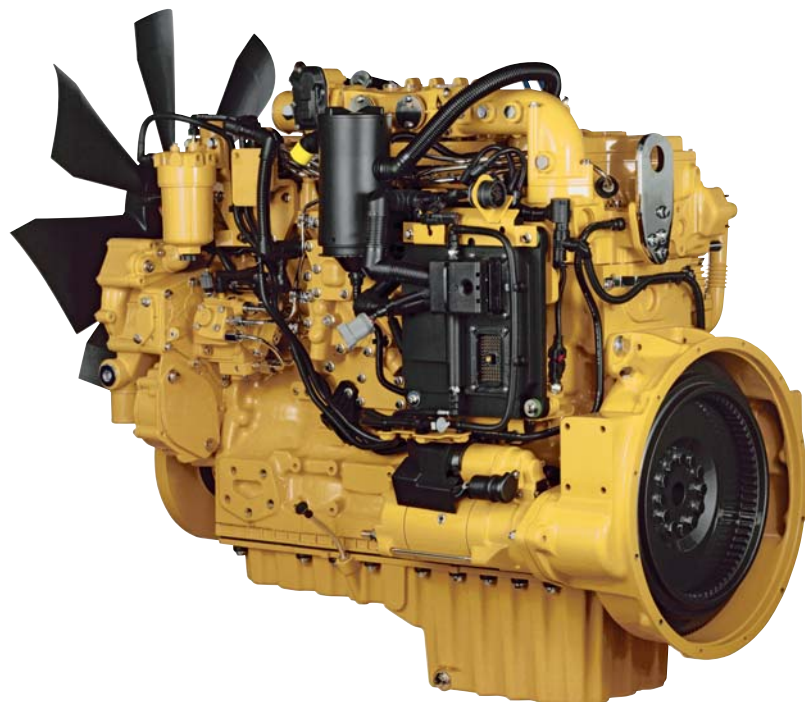

Emissions Technology

Reliable and transparent integrated solutions

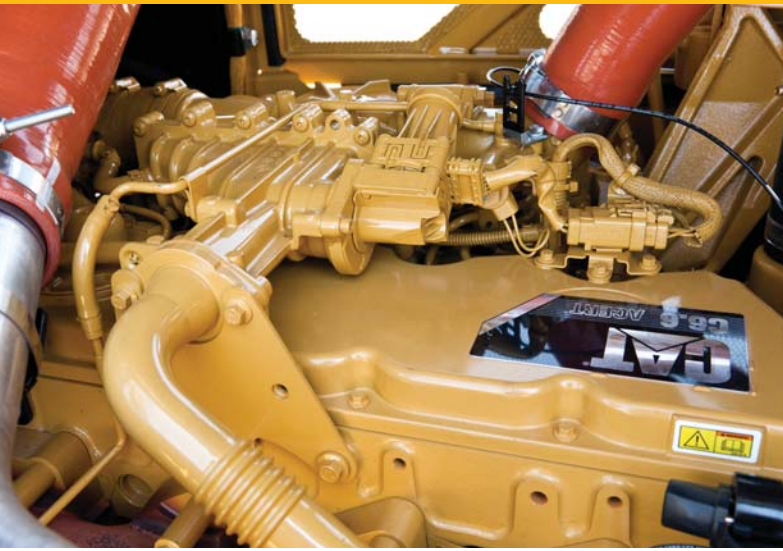

Cat NOx Reduction System

The Cat NOx Reduction System captures and cools a small quantity of exhaust gas, then routes it into the combustion chamber where it drives down combustion temperatures and reduces NOx emissions.

Aftertreatment Technologies

Cat aftertreatment components have been designed to match application needs. System components include a Diesel Oxidation Catalyst (DOC), which uses a chemical process to convert regulated emissions in the exhaust system, and a Diesel Particulate Filter (DPF) that traps and removes soot until burnt off through regeneration. The DOC and DPF are contained in the Clean Emissions Module (CEM) that protects the components and simplifies maintenance. The CEM will control if regeneration needs to occur and soot level is monitored through the display. The aftertreatment is designed to remove particulate matter from the exhaust without the need for operator intervention or work cycle interruption.

Cat Low Temperature Regeneration System

The low temperature Passive Regeneration system works transparently, without any interaction needed from the operator. Under most conditions, engine exhaust temperature will oxidize soot through passive regeneration. In certain operating conditions, when exhaust temperatures might not be high enough, a back pressure valve automatically increases engine load, therefore restoring necessary exhaust temperature. This ensures transparent regeneration even at low temperatures or low load factor.

Engine Idle Shutdown Timer – This option (when activated by the operator) shuts down the engine after the machine has been idling for a pre-set period of time.

Automatic Engine Speed Control (AESC) – It reduces engine speed when the machine is not under load for more than five seconds, which can help reduce fuel consumption significantly depending on the application.



Powertrain

Efficient, smooth and responsive power

The power shift transmission and differential steering work in tandem with the engine to deliver the power, productive performance and reliability expected from Cat track-type tractors.

High Efficiency Torque Divider

The torque divider acts as a hydrodynamic component between the engine and transmission to provide high multiplication of torque and attain the best combination of operating efficiency and driveline reliability.

Differential Steering System

Differential steering maintains full power to both tracks to provide best-in-class turning with a loaded blade. When one track speeds up, the other slows down an equal amount. Maneuverability is improved, as well as cycle times in some applications.

Multi Velocity Program (MVP)

Maximize your production and fuel efficiency with this exclusive feature, which let you choose from different engine speed ranges to best match your applications and ground conditions.

ECO Modes

Standard Eco Modes (when activated) automatically reduce engine speed and are suited for light to medium loaded applications. Operators can select either the “reverse only” or the “forward and reverse” mode. Eco Modes can help save up to 25% of fuel depending on the application.

Implement and Steering Controls

Ergonomically designed for ease of operation



All controls are electro-hydraulic, which means precision and maneuverability. They are ergonomically designed for easy intuitive, comfortable and low effort operation. Blade response can be adjusted through the operator profile in the display.

Steering and Transmission Controls: All in One Hand

Differential steering controls give the maneuverability and precision needed in close areas or around structures. The single handle controls the direction (FNR switch) and degree of turns, forward-reverse shifting and gear selection.

The thumb roller shifts the electronically controlled transmission and its Ground Speed Adjustment function enables precise speed control. The Speed Recall function allows you to easily save and recall the speed (forward) you want to operate with.



Dozer and Rear Attachment Control Levers

- **Dozer Control Joystick.** The lever allows six-way control of the VPAT blade and the thumb rocker adjusts the blade angle. Standard electro-hydraulic control means simplified installation of the AccuGrade™ system.
- **Integrated Ripper/Winch Lever.** Rear attachments are controlled by the same lever and controls can be pre-configured for a ripper, a winch or both of them.

Throttle Rocker Switch

Press the Throttle Rocker switch, it will adjust the engine speed to high or low idle. Press and hold until desired engine speed is attained and then release, the machine will maintain this new chosen speed.

Implement/Work Tool Lock-Out Switch

Lock-out feature prevents inadvertent operation of hydraulic work tool attachments.

Auto-Shift/Auto-Kickdown Switch

The Auto-Shift function allows a pre-selection of four forward and reverse speed settings that will occur automatically for easy, efficient directional changes. Auto-kickdown allows the transmission to automatically downshift when significant load increases are detected, maximizing your productivity.





Integrated Technologies

Solutions to make work easier and more efficient

AccuGrade Ready Option

The AccuGrade Ready Option (ARO) provides the pre-assembly that is required to make the AccuGrade machine control and guidance system installation quick and easy, ready to plug and play. The display support has been redesigned and makes the installation or removal of the display easier, thanks to two latches on the top of it.

AccuGrade

AccuGrade is a dealer installed machine control and guidance system which enables operators to cut and fill to grade with increased accuracy, minimizing the need for traditional stakes and grade checkers.

AccuGrade uses advanced Laser, Global Navigation Satellite System (GNSS) and/or Universal Tracking Station (UTS) technology, machine-mounted components and off-board hardware. This state-of-the-art machine control system provides precise elevation information on an in-cab display to achieve accurate blade positioning. By displaying real-time cut/fill information in the cab, operators can improve their efficiency and get to grade faster with fewer passes than ever before. The AccuGrade System significantly improves the productivity and accuracy of grading equipment – by as much as 50 percent over conventional methods.

Rough Grade

The D6N AccuGrade now includes the Rough Grade function; it allows the operator to control the tilt manually as long as the blade center is above design, while the AccuGrade system controls the blade height. When the blade center reaches the grade, an auto-lift control prevents the blade from going further down. This can increase your performance when operating manually.

Cat Product Link

Remote monitoring with Product Link improves overall fleet-management effectiveness. Product Link is deeply integrated into machine systems. Events and diagnostic codes, as well as hours, fuel, idle time and other detailed information are transmitted to a secure web based application, VisionLink™. VisionLink includes powerful tools to convey information to users and dealers, including mapping, working and idle time, fuel level and more.

Cooling System

Durable and efficient



The engine radiator, Air To Air After Cooler (ATAAC), and hydraulic oil cooler are packaged in a single plane. Aluminum bar plate construction provides durability and allows for higher heat transfer and superior corrosion resistance. The standard cores feature 8.9 fins per inch (6.5 fins per inch for the Waste Handling Arrangement) to allow debris to pass through and reduce plugging.

The engine mounted demand fan provides engine cooling capability that is matched to the ambient conditions. Fan speed is adapted to the cooling load and reduced when it is not needed to save fuel.

An optional manual reversible fan (only available as direct drive) allows fan blades to be reversed manually to get opposite cooling air flow when ambient temperature is low.

A sand blast grid can be located between radiator and fan and protects radiator from abrasive materials and debris.

The new engine air filter strategy includes a cyclone precleaner that can be cleaned up several times simply with pressurized air.

The air conditioner is mounted at the rear of the cab for optimum ambient capability.



Undercarriage

Robustness and Performance

The D6N features the elevated sprocket design that isolates final drives, axles, and steering components from harsh impacts. The modular design aids to reduce maintenance costs. A variety of undercarriage configurations and track shoe designs help optimize performance.

SystemOne™ Undercarriage

SystemOne can help reduce owning and operating costs in many applications. Lifetime sealed and lubricated cartridges eliminate bushing turns and sprockets require no replacement during the life of the chain. All SystemOne undercarriage components are designed to work and wear as a system for longer track life.

Heavy Duty Undercarriage

Heavy duty undercarriage is well-suited to aggressive applications like land clearing, side-slopes, or working in rocky or uneven terrain. Components are designed for extended wear life in abrasive conditions and high impact applications.

XL, LGP and XL Fine Grading Versions

The XL version performs well in applications with firm to soft underfoot conditions. The LGP undercarriage is designed for soft and swampy conditions. The XL Fine Grading version combines the LGP roller frame length with XL shoes for finish grading applications. All machines now have a stiffer equalizer bar, which enhances finish grading capabilities.

Work Tools

Equipped for the job



Load Sensing Hydraulics

Field-proven, load-sensing hydraulics respond to operating requirements by automatically and continually adjusting hydraulic power to maximize work tool efficiency.

Bulldozer and Blade Design

The D6N features a new large spherical linkage bearing for an easier blade removal. Linkage bearings are designed for the life of the machine.

VPAT blades now come AccuGrade Ready from factory with mounted brackets for AccuGrade receivers. AccuGrade angle sensor are better protected in the new centered position. Strong design allows Cat blades to stand up to the most severe applications.

Variable Pitch Angle Tilt (VPAT) Blade

This blade allows the operator to adjust the blade lift, angle and tilt simultaneously, using the same control. The blade pitch can also be adjusted, which can help increase productivity. Changing the blade pitch angle is now easier with the new pitch system.

The versatility of the VPAT blade gives the D6N the ability to take on a variety of applications and material conditions, such as finish grading, spreading material or backfilling. Full track coverage can be achieved in one pass.

VPAT Foldable Blade

Designed to facilitate transportation without blade removal, foldable blades reduce the overall shipping width. The blade can be easily folded without the need for tools, and its design has been improved to make the folding process easier and quicker, with only one pin left to remove.

Semi-Universal (SU) Blades (for XL versions only)

This blade is built for tough applications where penetration and capacity are important. L-shaped push arms bring the blade closer to the machine, providing excellent maneuverability, balance and stability. When end bits are removed, the blade width reduces to 3 m (9.8 ft) to allow easier transportation.



Rear Implements

Increased versatility

Multi-Shank Ripper

Parallelogram linkage design allows for better penetration and maneuverability in tight working areas.

Winch

For improved winch availability and configuration flexibility, dealers may order the D6N with a factory installed winch preparation package to allow the winch to be easily installed in the field. A single lever control actuates both clutch and brake functions to help improve operator efficiency. See your Cat dealer for available winch options.

A dual control package is also available for machines that can be fitted either with a ripper or a winch.

Drawbar

The D6N can be equipped with a drawbar for retrieving other equipment or pulling work tools such as discs, compactors, or chopper wheels.

Sustainability

Thinking generations ahead



The Cat D6N is designed to benefit your business, and reduce emissions.

- Meets U.S. Tier 4 Interim, EU Stage IIIB and Japan MLIT Step 4.
- Fuel efficient engine, and features like the new Eco Modes Reverse and Forward/Reverse, Auto Engine Speed Control and the viscous clutch demand fan, help decrease overall fuel consumption.
- Technologies like AccuGrade and Product Link help improve overall efficiency, save fuel and fluids, as well as wear and tear on equipment.
- The D6N can be run on Biodiesels (20% maximum, mixed with Ultra Low Sulfur Diesel Fuel) without reducing the life of the system. Biodegradable hydraulic oil is also available.
- Standard ecology drains provide an environmentally safer method to drain fluids from major components.
- Great visibility, grab handles, steps, remote pressure ports accessible from ground level help enhance job site safety.
- Major components are built to be rebuilt, eliminating waste and saving customers money by giving the machine and/or major components a second – and even third – life.



Value Packages

Get more for less.

Feature Packages

Ripper or Winch Ready Packages – Includes hydraulics, wiring and controls that are necessary to install a ripper or a winch to increase flexibility and reduce downtime.

Dual Control Ready Package – Offers versatility for customers who want to use a ripper and a winch on the same machine. Includes a common lever for both attachments and the necessary hydraulics to make installation easier.

Maintenance Package – Includes fast fuel and high speed oil change capability.

Application packages

Various Heavy Duty Guard Packages – Several guard packages are available. Contact your Cat dealer for more information on these packages.

Forestry Package – This package includes several heavy duty guards for land clearing and forestry applications. Extensive Guarding helps protect critical machine components. A debris resistant cooling system helps reduce plugging and extend service life.

Waste Handling Package – Recommended for Landfill applications, it includes several Heavy Duty guards, protections and special final drive / Idler seal guards. They help keep damaging wires or debris out of the final drive and idler seals.

Improved Cold Weather Package – The standard machine includes glow plugs allowing a properly maintained engine to start at minus 18° C (0° F) with standard oil. The cold weather package includes ether starting aid, heavy duty batteries and 120V/240V jacket water heater that can bear temperatures below 18° C (0° F) with cold fluids at sea level. An optional electrical heated and insulated breather canister with a special coolant can bear -50° C (58° F).

Contact custom products for waste handling, forestry and other specific application requirements.

Serviceability and Customer Support

When uptime counts



Accessible, Quick and Easy Maintenance

Hinged engine doors provide easy access to grouped maintenance points. The engine air filter can be easily removed for inspection. A standard electric priming pump reduces efforts and time to prime the system. Service doors on the rear provide easy access to grouped pressure taps for quick testing of the Hydraulic system. A grease gun holder is located on the rear compartment.

Secured Maintenance

Steps and handles make climbing on and off the tractor easy and safe. Anti-slip surfaces are located on every needed surface for more safety while moving on the machine.

Operator Presence Detection strategy and work tools lock-out provide additional protection by preventing unintentional movements that could make the machine move.

Maintenance Monitoring

Diagnostic connectors allow Cat dealers to quickly troubleshoot the machine. The flexible monitoring system offers more diagnostic capabilities like the engine oil low level. These features are blacked up by the Product Link.

Robust, Convenient and Modular Design

Components are designed to be robust with structures reducing stress concentration and interferences. The modular design allows them to be easily removed without removing others. This means less service time.

Renowned Cat Dealer Support

From helping you choose the right machine to knowledgeable ongoing support, Cat dealers provide the best in sales and service. Manage costs with preventive maintenance programs like Scheduled Oil Sampling (S·O·SSM) analysis, and guaranteed maintenance contracts. Stay productive with best-in-class parts availability. Cat dealers can even help you with operator training to help boost your profits. And when it's time for machine replacement, your Cat dealer can help you save even more with Genuine Cat Remanufactured parts. Receive the same warranty and reliability as new products at cost savings of 40 to 70 percent for powertrain and hydraulic components.

D6N Track-Type Tractor Specifications

Engine

Engine Model	Cat® C6.6 ACERT™	
Emissions	U.S. Tier 4 Interim, EU Stage IIIB, Japan MLIT Step 4	
Gross Power – SAE J1995	132 kW	177 hp
Engine Power – ISO 14396	129 kW	173 hp
Engine Power – ISO 14396 (DIN)	175.3 hp	
Net Power – ISO 9249	112 kW	150 hp
Net Power – ISO 9249 (DIN)	152 hp	
Net Power – SAE J1349	110.4 kW	148 hp
Net Power – EU 80/1269/EEC	112 kW	150 hp
Engine Speed 1,850 rpm – Net Power	116.8 kW	156.6 hp
Bore	105 mm	4.13 in
Stroke	127 mm	4.99 in
Displacement	6.6 L	402.75 in ³

- Engine Ratings at 2,200 rpm.
- Net power advertised is the power available at the engine flywheel when the engine is equipped with the air cleaner, muffler, alternator, A/C compressor at full load, cooling fan at max speed.
- No derating required up to 3000 m (9,840 ft) altitude, beyond 3000 m (9,840 ft) automatic derating occurs.

Transmission

1.5 Forward	3.1 km/h	1.93 mph
2.0 Forward	4.6 km/h	2.86 mph
2.5 Forward	5.7 km/h	3.54 mph
3.0 Forward	7.5 km/h	4.66 mph
3.5 Forward	10 km/h	6.21 mph
1.5 Reverse	3.1 km/h	1.93 mph
2.0 Reverse	5.1 km/h	3.17 mph
2.5 Reverse*	6.4 km/h	4 mph
3.0 Reverse*	8.5 km/h	5.28 mph
3.5 Reverse*	11.6 km/h	7.21 mph
1.5 Forward – Drawbar Pull	320 kN	71,939 lb
2.5 Forward* – Drawbar Pull	175 kN	39,341.6 lb
3.5 Forward* – Drawbar Pull	97 kN	21,806.5 lb

* Eco Modes disabled. With Eco Modes enabled, speed settings will change.

Service Refill Capacities

Fuel Tank	299 L	79 gal
Cooling System	40 L	10.56 gal
Final Drives (each)	8.5 L	2.25 gal
Hydraulic Tank	29.5 L	7.79 gal

Weights

Weight*	1276.5 kg	2,814 lb
Operating Weight – XL	16 507 kg	36,392 lb
Operating Weight – LGP	18 096 kg	39,895 lb
Shipping Weight – XL	16 149 kg	35,602 lb
Shipping Weight – LGP	17 594 kg	38,788 lb
XL VPAT Blade	1062 kg	2,341 lb
LGP VPAT Blade	1234 kg	2,720 lb
XL VPAT Foldable	1253 kg	2,762 lb
LGP VPAT Foldable	1491 kg	3,287 lb
XL SU Blade	2600 kg	5,732 lb
XL VPAT Landfill	1321 kg	2,912 lb
LGP VPAT Landfill	1436 kg	3,166 lb
Multi-shank Ripper (with 3 shanks)	1562 kg	3,444 lb
Winch PA55	See value and note, next page	

- Operating Weight: Includes EROPS, A/C, lights VPAT dozer, transmission, drawbar, engine enclosure, 3-valve hydraulics, 100% fuel, and Cat Comfort Series Air Suspension Seat and operator.
- Shipping Weight: Includes EROPS, A/C, lights VPAT dozer, transmission, drawbar, engine enclosure, 3-valve hydraulics, 5% fuel, and Cat Comfort Series Air Suspension Seat.
- * Weight: Includes pump, operator controls, oil, mounting brackets and spacers.

Undercarriage

Width of Shoe – XL	610 mm	24.01 in
Width of Shoe – LGP	840 mm	33.07 in
Shoes/Side – XL	40	
Shoes/Side – LGP	46	
Grouser Height – XL	66 mm	2.6 in
Grouser Height – LGP	57 mm	2.2 in
Track Gauge – XL	1890 mm	74.4 in
Track Gauge – LGP	2160 mm	85.03 in
Track on Ground – XL	2611 mm	102.8 in
Track on Ground – LGP	3113 mm	122.56 in
Ground Contact Area – XL	3.18 m ²	4,929 in ²
Ground Contact Area – LGP	5.23 m ²	8,107 in ²
Ground Pressure* – XL	45.2 kPa	6.55 psi
Ground Pressure* – LGP	30.4 kPa	4.41 psi
Track Rollers/Side – XL	7	
Track Rollers/Side – LGP	8	

* ISO 16754

Drawbar Pull

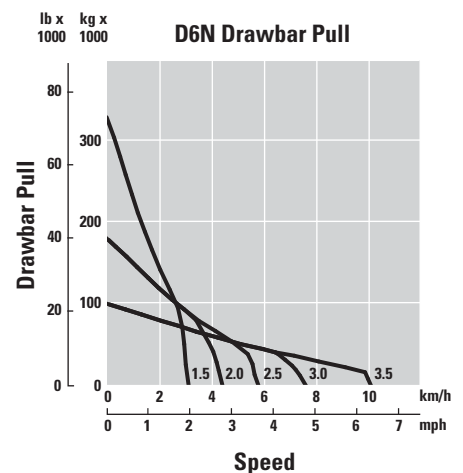

The direct injection electronic fuel system provides a controlled fuel delivery increase as the engine lugs back from rated speed. This results in increased horsepower. A combination of increased torque rise and maximum horsepower improves response, provides greater drawbar pull and faster dozing cycles.

D6N Track-Type Tractor Specifications

Blades

Blade Type	VPAT, SU	
XL VPAT – Blade Capacity	3.18 m ³	4.16 yd ³
LGP VPAT – Blade Capacity	3.16 m ³	4.13 yd ³
LGP VPAT Foldable Blade Capacity	3.16 m ³	4.13 yd ³
XL SU – Blade Capacity	4.28 m ³	5.6 yd ³
XL VPAT – Blade Width	3272 mm	10 ft 9 in
LGP VPAT – Blade Width	4080 mm	13 ft 5 in
LGP VPAT Foldable Blade Width	4080 mm	13 ft 5 in
XL SU – Blade Width	3154 mm	10 ft 4 in
XL SU – Narrow* Blade width	3000 mm	9 ft 10 in

* For Europe only; Width is with end bits removed; Blade width with end bits is 3126 mm (10 ft).

Ripper

Type	Fixed Parallelogram	
Pocket Spacing	1000 mm	3 ft 3.4 in
Shank Gauge	2 m	6 ft 7 in
Shank Section	73 mm × 176 mm 2.9 in × 6.9 in	
Number of Pockets	3	
Overall Beam Width	2202 mm	86.7 in
Beam Cross Section	216 mm × 254 mm 8.5 in × 10.0 in	
Maximum Clearance, Raised (Shank Tip)	622 mm	24.5 in
Maximum Penetration Force – XL	51.6 kN	11,600 lbf
Maximum Pry-out Force – XL	211.2 kN	47,480 lbf
Maximum Penetration Force – LGP	43 kN	9,667 lbf
Maximum Pry-out Force – LGP	170 kN	38,217 lbf
Number of Pockets in Ripper Beam	3	
Maximum Penetration – XL	514 mm	20.2 in
Maximum Penetration – LGP	398 mm	15.6 in
Each Additional Shank	78 kg	172 lb
Weight: with 3 Shanks	1562 kg	3,444 lb

Winch

Winch Model	PA55	
Oil Capacity	74 L	19.55 gal
Winch and Bracket Length	1145 mm	45.1 in
Winch Case Width	975 mm	38.4 in
Drum Diameter	254 mm	10 in
Drum Width	315 mm	12.4 in
Flange Diameter	504 mm	19.8 in
Drum Capacity – 22 mm (0.88 in)	88 m	288 ft 9 in
Winch Drive	Mechanical	
Control	Electric	
Overall Width	975 mm	38.4 in
Rope Diameter (recommended)	19 mm	0.75 in
Cable Ferrule Size (O.D. × Length)	54 mm × 67 mm	2.13 in × 2.63 in
Maximum Bare Drum		
Line Pull	31 388.5 kg	69,200 lb
Line Speed	44.8 m/min	147 ft/min
Maximum Full Drum		
Line Pull	23 539 kg	54,100 lb
Line Speed	78.3 m/min	257 ft/min

• Slow and standard speed winches are available.

Standards

ROPS/FOPS	ROPS (Rollover Protective Structure) offered by Caterpillar for the machine meets ROPS criteria SAE J1040-1994, ISO 3471:2008 and DLV criteria SAE J397B-2009, ISO 3164:1995. FOPS (Falling Object Protective Structure) meets ISO 3449-2005 Level II and DLV criteria SAE J397B-2009, ISO 3164:1995.
Brakes	Brakes meet the standard ISO 10265:2008

Sound Information and Vibration Information – Cab

Sound Level Information

- The declared operator Equivalent Sound Pressure Level (Leq) is 83 dB(A) when “ANSI/SAE J1166 FEB2008” is used to measure the value for an enclosed cab. The measurement was conducted at 100% of the maximum engine cooling fan speed. This is a work cycle sound exposure level. The cab was properly installed and maintained. The test was conducted with the cab doors and the cab windows closed.
- Hearing protection may be needed when the machine is operated with an open operator station for extended periods or in a noisy environment. Hearing protection may be needed when the machine is operated with a cab that is not properly maintained, or when the doors and windows are open for extended periods or in a noisy environment.
- The declared average exterior sound pressure level is 83 dB(A) when the “SAE J88 FEB2006 – Constant Speed Moving Test” procedure is used to measure the value for the standard machine. The measurement was conducted under the following conditions: distance of 15 m (49.2 ft) and “the machine moving forward in an intermediate gear ratio.”

Sound Level Information for Machines in European Union Countries and in Countries that Adopt the “EU Directives”

The information below applies to only the machine configurations that have the “CE” mark on the Product Identification Plate.

- The declared dynamic operator sound pressure level is 78 dB(A) when “ISO 6396:2008” is used to measure the value for an enclosed cab. The measurement was conducted at 100% of the maximum engine cooling fan speed. The sound level may vary at different engine cooling fan speeds. The cab was properly installed and maintained. The measurement was conducted with the cab doors and the cab windows closed.
- If equipped, the certification label – 110 dB(A) – is used to verify the environmental sound certification of the machine to the requirements of the European Union. The value that is listed on the label indicates the guaranteed exterior sound power level (Lwa) at the time of manufacture for the conditions that are specified in “2000/14/EC.” Your machine may have a different value.

Sustainability – Sound and Vibration Levels

Sound Levels

Average Exterior Sound Pressure Level	83 dB(A) SAE J88:2006
Maximum Sound Power Level	110 dB(A) 2000/14/EC
Dynamic Operator Sound Pressure Level (LpA)	78 dB(A) ISO 6396:2008

Vibration Levels

Maximum Hand/Arm*	2.5 m/s ² ISO 5349:2001
Maximum Whole Body*	0.5 m/s ² ISO/TR25398:2006
Seat Transmissibility Factor	<0.7 ISO 7096:2000 – spectral class EM6

* Values are for an experienced operator in a dozing application, consult the Operating and Maintenance Manual for further details.

D6N Track-Type Tractor Specifications

Dimensions

(approximate)

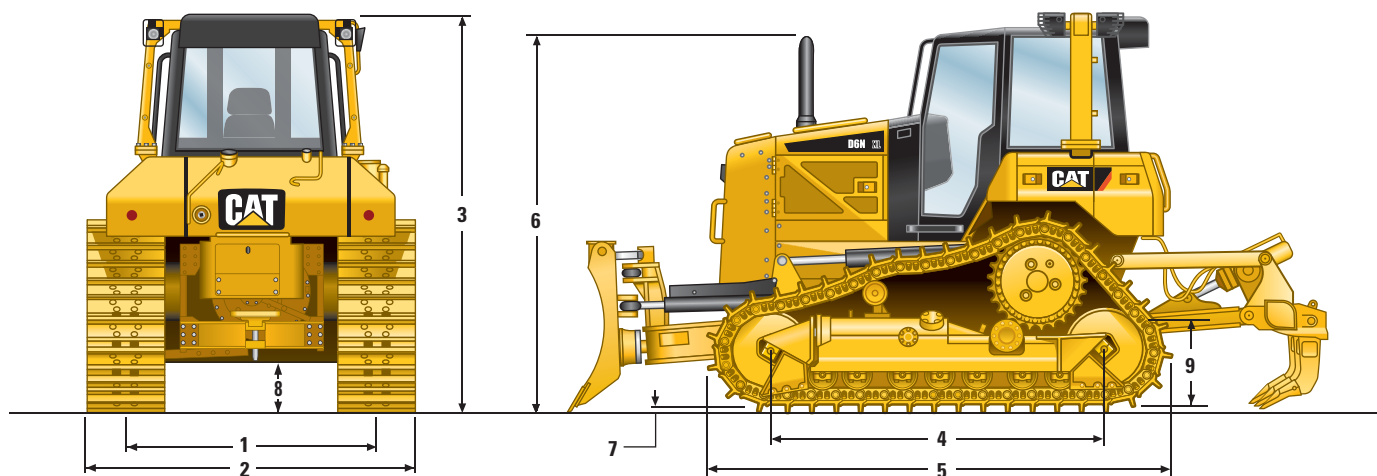

Tractor Dimensions

	XL		LGP		XL Fine Grading	
1 Track gauge	1890 mm	74.4 in	2160 mm	85 in	1890 mm	74.4 in
2 Width of tractor	With the following attachments:					
Standard shoes without blade	2500 mm	98.4 in	3000 mm	118 in	2500 mm	98.4 in
Standard shoes with VPAT blade fully angled	2965 mm	116.7 in	3699 mm	145.6 in	2965 mm	116.7 in
Standard shoes with VPAT blade angled and folded (foldable blade only)	2545 mm	100 in	3000 mm	118 in	2545 mm	100 in
3 Machine height – ROPS cab:	From tip of grouser					
	3088 mm	121.57 in	3202 mm	126 in	3202 mm	126 in
	From ground face of shoe					
	3031 mm	119.3 in	3145 mm	123.8 in	3145 mm	123.8 in
4 Length of track on ground	2643 mm	104.0 in	3116 mm	122.6 in	3206 mm	126 in
5 Length of basic tractor (with drawbar)	3740 mm	147.2 in	4194 mm	165 in	4194 mm	165 in
With the following attachments, add to basic tractor length:						
Ripper (with tip at ground line)	1026 mm	40.4 in	1026 mm	40.4 in	1026 mm	40.4 in
PA55 winch	381 mm	15 in	381 mm	15 in	381 mm	15 in
VPAT blades, straight	1163 mm	45.8 in	1705 mm	67.1 in	1705 mm	67.1 in
VPAT blade, angled 25°	1787 mm	70.4 in	2487 mm	87.9 in	2329 mm	91.7 in
SU blade	1417 mm	55.8 in	—	—	—	—
6 Height over stack from tip of grouser	2979 mm	117.3 in	3083 mm	121.4 in	3083 mm	121.4 in
7 Height of grouser	66 mm	2.6 in	57 mm	2.2 in	57 mm	2.2 in
8 Ground clearance from ground face of shoe (per SAE J1234)	394 mm	15.5 in	507 mm	20.0 in	507 mm	20 in
9 Drawbar height (grouser tip to center of clevis)	From ground face of shoe					
	595 mm	22.2 in	710 mm	28 in	710 mm	28 in

Standard Equipment

Standard equipment may vary. Consult your Cat dealer for details.

ELECTRICAL

- Horn
- Hour meter
- Back-up alarm
- 12V converter, 10A
- Diagnostic connector
- 950 CCA class 31 batteries
- Integrated lights four (4) front and two (2) rear
- 105 Amp HD brushless alternator (24 Volt)
- 24 Volt heavy duty electric starter

OPERATOR ENVIRONMENT

- ROPS/FOPS cab
- Integrated A/C with automatic temperature control
- Seat, air suspension, cloth for cab
- 76 mm (3 in) retractable seat belt
- Adjustable armrests
- Foot rests for slope work
- Gen III five gauge instrument cluster with:
 - Engine coolant temperature
 - Transmission oil temperature
 - Hydraulic oil temperature
 - Fuel level
 - Engine RPM display/gear display
 - Operator profile
 - Electronically programmable gear selector
 - Electronic engine air cleaner service indicator
 - Electronic water-in-fuel sensor service indicator
- Electro-hydraulic implement control
- Electro-hydraulic tiller bar differential steering control
- Product Link ready
- One (1) 12 volt power points
- 12V radio ready (plug and play)
- Storage compartment
- Cup holder (LH)
- Coat hook
- Rearview mirror

POWER TRAIN

- C6.6 Cat ACERT diesel engine with aftertreatment, EPA/ARB Tier 4 Interim/ EU Stage IIIB and Japan MLIT Step 4 certified; common rail fuel system, ADEM A5 Electronic Control Module, and an air-to-air aftercooling; single poly-vee belt with auto belt tensioner
- Glowplug starting aid
- 3000 m altitude (9,840 ft) operation capability before derating
- Engine driven viscous clutch fan
- Aluminum bar plate cooling system (radiator, power train, aftercooler)
- Steel tube-fin differential steer oil cooler
- Air cleaner with integrated precleaner, automatic dust ejector and under hood air intake
- Electric fuel lift pump with automatic priming function
- Two (2) fuel filters
- Engine decelerating function (toggle switch and pedal engine speed control)
- Three (3) speed planetary, power-shift transmission with torque converter
- System MVP: multiple speed functionality providing 5 discrete ground speed selections and electronic control enhancements for the transmission/engine system
- Controlled throttle shifting with automatic load compensation
- Automatic down-shift and kick-down transmission control
- Selectable auto-shift (1F-2R, 2F-2R, selectable)
- Steering system: differential steering with electro-hydraulic control tiller bar

UNDERCARRIAGE

- SystemOne undercarriage for XL and LGP undercarriages
- Relieved tread idler
- Lifetime lubricated track rollers (7 XL and 8 LGP) and idler
- Carrier roller
- Replaceable sprocket rim segments
- Tracks 40 section – 610 mm (24 in) Extreme Service (ES) for XL
- Tracks 46 section – 840 mm (33 in) Moderate Service (MS) for LGP
- Hydraulic track adjusters
- Replaceable sprocket rim segments

HYDRAULICS

- Three (3) valve-hydraulics for VPAT dozer
- Load sensing hydraulics

FLUIDS

- Antifreeze coolant (–37° C/–34.6° F)
- Extended life coolant
- Cat HYDO Advanced 10 Hydraulic Fluid

OTHER STANDARD EQUIPMENT

- C Frame, cylinders (VPAT) and lines
- Bulldozer VPAT XL or LGP Standard Package
- Extended service intervals (500 hours engine, 1,000 hours power train)
- Crankcase guard
- Ecology drains (engine oil, engine coolant, power train case, hydraulic)
- Scheduled Oil Sampling ports (engine, power train, hydraulics)
- Centralized remote mounted pressure taps for easy access and diagnostics
- Implement oil filter
- Front pull device
- Hinged radiator louvered grill
- Lockable engine enclosures
- Rigid drawbar
- Guard rear standard

D6N Optional Equipment

Optional Equipment

Optional equipment may vary. Consult your Cat dealer for details.

FEATURE PACKAGES

- Application Packages
 - Forestry Protection, XL Package
 - Forestry Protection Package LGP
 - Waste Handling Package XL for SystemOne and Heavy Duty U/C
 - Waste Handling Package LGP for SystemOne and Heavy Duty U/C
- Rear Control Packages
 - Ripper Ready Package
 - Winch Ready Package
 - Dual Control Package, VPAT
 - Dual Control Package, SU
 - No Rear Attachment, VPAT
- Protection Packages
 - Cab, Protection Package
 - Handle, No Sweeps

POWER TRAIN

- Precleaner, Turbine with Screen
- Direct Drive Fan, Manual Reversible
- Grid, Sandblast

COOLING

- Radiator, Trash Resistant

UNDERCARRIAGE

- **XL Undercarriage**
 - Undercarriage, SystemOne, XL
 - Undercarriage, Heavy Duty, XL
 - U/C HD High Double Flange, XL
 - U/C Waste SystemOne, XL
 - U/C Waste Heavy Duty, XL
 - U/C Fine Grading SystemOne, XL
 - U/C Fine Grading Heavy Duty, XL
- **LGP Undercarriage**
 - Undercarriage, SystemOne, LGP
 - Undercarriage, Heavy Duty, LGP
 - U/C HD High Double Flange, LGP
 - U/C Waste SystemOne, LGP
 - U/C Waste Heavy Duty, LGP
- **Track Pairs, XL, SystemOne**
 - Track, 560 mm (22 in), ES, XL
 - Track, 610 mm (24 in), ES, XL
 - Track, 610 mm (24 in), ES, Center Hole, XL
 - Track, 610 mm (24 in), MS, Fine Grading Undercarriage
- **Track Pairs, XL, HD**
 - Track, 600 mm (23.6 in), ES, XL, HD
 - Track, 600 mm (23.6 in), ES Center Hole, XL, HD
 - Track, 600 mm (23.6 in), MS, XL, HD, Fine Grading Undercarriage
- **Track Pairs, LGP, SystemOne**
 - Track, 840 mm (33 in), ES, LGP
 - Track, 840 mm (33 in), MS, LGP

- Track, 860 mm (33.8 in), ES, LGP (ADSDN only)
- **Track Pairs, LGP, HD**
 - Track, 840 mm (33 in), ES, LGP, HD
 - Track, 840 mm (33 in), ES, Center Hole, LGP, HD
 - Track, 860 mm (33.8 in), ES, LGP, HD
 - Track, 865 mm (34 in), Self Clean

TRACK GUIDING GUARDS ARRANGEMENTS

- **Track Guiding Guards, XL, SystemOne**
 - Guard Guiding, Center
 - Guard Guiding, Front and Rear
 - Guard Guiding, Full
- **Track Guiding Guards, XL, HD**
 - Guard Guiding Center, HD
 - Guard Guiding, Front and Rear
 - Guard Guiding, Full
- **Track Guiding Guards, LGP, SystemOne**
 - Guard Guiding, Center
 - Guard Guiding, Front and Rear
 - Guard Guiding, Full
- **Track Guiding Guards, LGP, HD**
 - Guard Guiding Center, HD
 - Guard Guiding, Front and Rear

HYDRAULICS

- Oil, Bio Hydr., Factory Filled

STARTERS, BATTERIES AND ALTERNATORS

- Weather Packages and Batteries
- Cold Weather, 120V, Package
- Cold Weather, 240V, Package
- Battery, Heavy Duty
- Electrical Insulated Breather

FLUIDS

- Antifreeze, –50° C (–58° F)

OPERATOR ENVIRONMENT

- Seat, Heated
- Seat, Heated and Ventilated

TECHNOLOGY PRODUCTS

- Product Link Communications
 - Cat Product Link 321 – Satellite
 - Cat Product Link 522 – Cellular
 - No Product Link (For countries where the Product Link is not certified for use)
- AccuGrade Control
 - ARO Installation, VPAT
 - AccuGrade ARO, SU
 - No AccuGrade Installation SU (For SU machines not AccuGrade Ready)
- Machine Security Systems
 - Security System, Machine

FUEL SYSTEMS

- Tank, Fuel
 - Maintenance Package/ Shaw Fast Fill System

GUARDS

- Protection Packages
 - Guard, VPAT, Heavy Duty, Package
 - Guard Package Standard, SU
 - Guard Package Heavy Duty, SU
- Rear Hydraulic Protections
 - Guard, Rear, Heavy Duty
 - Guard, Rear, Winch Ready and Drawbar
 - Guard, Vandalism, Rear
 - Guard, Vandalism, Rear (HD)
- Protection
 - Screen, Protective, Cab

OTHER ATTACHMENTS

- Rear Hydraulics
 - PTO Filter, Winch – Low
 - PTO Filter, No Winch

BLADES

- Bulldozer Package
 - Bulldozer, SU XL, Package – Complete with Blade Included
 - Bulldozer, VPAT XL, HD, Package
 - Bulldozer, VPAT LGP, HD, Package
- Blades
 - Blade XL, ARO, VPAT
 - Blade LGP, ARO, VPAT
 - Blade XL, ARO Foldable, VPAT
 - Blade LGP, ARO Foldable, VPAT
 - Blade XL, Landfill
 - Blade LGP, Landfill

GROUND ENGAGING TOOLS

- Ripper
 - Ripper, Teeth Straight, Package
 - Ripper, Teeth Curved, Package
- Winch
 - PA56 Winch Package, Standard Speed
 - PA56 Winch Package, Slow Speed
 - Rear Box with Striker Bar

ELECTRICAL

- Beacon, Rotating

FIELD INSTALLED ATTACHMENTS –

To Order From Parts Distribution

- Radio, AM/FM CD Player
- Retrofit Kit Cloth Heated
- Fairlead, Lane 3 Only – Not Installed
 - Fairlead, 3 Rollers
 - Fairlead, 4 Rollers

For more complete information on Cat products, dealer services, and industry solutions, visit us on the web at www.cat.com

AEHQ6684-01 (05-2013)
Replaces AEHQ6684

© 2013 Caterpillar Inc.
All rights reserved

Materials and specifications are subject to change without notice. Featured machines in photos may include additional equipment. See your Cat dealer for available options.

CAT, CATERPILLAR, SAFETY.CAT.COM, their respective logos, "Caterpillar Yellow" and the "Power Edge" trade dress, as well as corporate and product identity used herein, are trademarks of Caterpillar and may not be used without permission.

