



Cat[®] CM235

CONTINUOUS MINER

Specifications

Operating Dimensions

Mining Range (recommended)	1067-2946 mm	42-116 in
Minimum Height	914 mm	36 in
Maximum Reach	3251 mm	10 ft 8 in
Ground Clearance	229 mm	9 in
Length Rear Bumper to Face	8160 mm	26 ft 9 in

Transport Dimensions

Frame Width (over rub rails)	3277 mm	10 ft 9 in
Overall Length	11 049 mm	36 ft 3 in
Height (over scrubber duct)	914 mm	36 in

Machine Weight

Weight (total)	61.2 tonnes	135,000 lb
----------------	-------------	------------

Cutting Unit

Cutting Drum Diameter	914 mm	36 in
Cutting Drum Width	3581 mm	11 ft 9 in
Cutting Power – Motors (one-hour rating)	2 × 205 kW	2 × 275 hp

Loading Unit

Loading Method	6-finger CLA	
Conveyor Width	965 mm	38 in
Conveyor Depth	152 mm	6 in
Loading Capacity	14-29 tonnes/min	15-32 tons/min
Conveyor Power – Motors (one-hour rating)	2 × 45 kW	2 × 60 hp

Traction Unit

Crawler Chain Width	508 mm	20 in
Crawler Assembly Length	2896 mm	9 ft 6 in
Ground Pressure	204 kPa	29.6 psi
Crawler Speed	0-26 m/min	0-85 fpm
Traction Power – AC/VFD (one-hour rating)	2 × 82 kW	2 × 110 hp

Pump Unit

Pump Power – Motor (one-hour rating)	1 × 37 kW	1 × 50 hp
--------------------------------------	-----------	-----------

Optional Dust Suppression

Scrubber Assembly	Top mounted, dual intake (bidirectional discharge)	
Scrubber Type	Wet bed	
Scrubber Capacity	2.8 m ³ /sec	6,000 ft ³ /min
Fan Power – Motor	1 × 22 kW	1 × 30 hp

Electrical System

Machine Voltage (International voltages available)	950V AC 60 Hz
Control System	Processor based/ radio remote control

Total Installed Power

One-hour Rating without Scrubber	701 kW	940 hp
----------------------------------	--------	--------

CM235 Continuous Miner

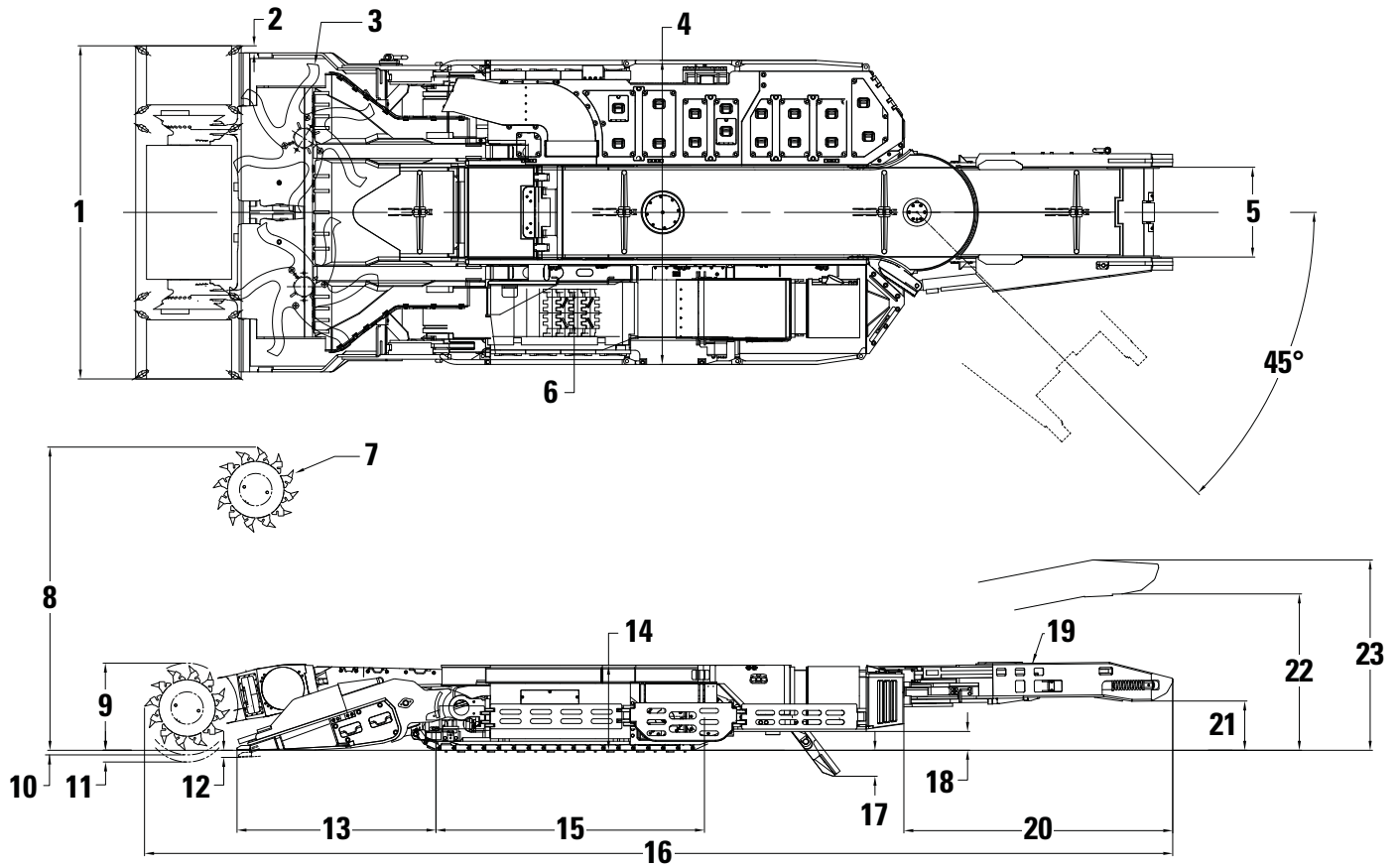

Dimensions (All dimensions are approximate.)

1	3581 mm	11 ft 9 in	13	2134 mm	7 ft 0 in
2	76 mm	3 in	14	914 mm	36 in
3	1600 mm	63 in	15	2896 mm	9 ft 6 in
4	3277 mm	10 ft 9 in	16	11 049 mm	36 ft 3 in
5	965 mm	38 in	17	279 mm	11 in
6	508 mm	20 in	18	229 mm	9 in
7	914 mm	36 in	19	152 mm	6 in
8	3251 mm	10 ft 8 in	20	2889 mm	9 ft 5.75 in
9	914 mm	36 in	21	527 mm	1 ft 8.75 in
10	51 mm	2 in	22	1683 mm	5 ft 6.25 in
11	127 mm	5 in	23	2045 in	6 ft 8.5 in
12	76 mm	3 in			

For more complete information on Cat products, dealer services, and industry solutions, visit us on the web at www.cat.com

AEHQ6873 (08-12)

© 2012 Caterpillar
All Rights Reserved
Printed in U.S.A.

Materials and specifications are subject to change without notice. Featured machines in photos may include additional equipment. See your Cat dealer for available options.

CAT, CATERPILLAR, SAFETY.CAT.COM, their respective logos, "Caterpillar Yellow" and the "Power Edge" trade dress, as well as corporate and product identity used herein, are trademarks of Caterpillar and may not be used without permission.

