

# 390F L

Hydraulic Excavator



## Engine

Engine Model	Cat® C18 ACERT™
Power – ISO 14396 (metric)	405 kW (551 PS)
Power – ISO 9249 (metric)	391 kW (532 PS)

## Drive

Maximum Travel Speed	4.5 km/h
Maximum Drawbar Pull	590 kN

## Operating Weights

Minimum – Reach Configuration	86 275 kg
Maximum – Mass Configuration	92 020 kg

**The 390F L is built to keep your production numbers up and your owning and operating costs down.**

*Not only does the machine's C18 ACERT engine meet EU Stage IV emission standards, but it does so while giving you all the power, fuel efficiency, and reliability you need to succeed.*

*Where the real power comes in is through the hydraulic system. You can literally move tons of material all day long with a great deal of speed and precision. In fact, the hydraulic system and engine work together to keep fuel consumption to an absolute minimum – all without impacting your productivity.*

*When you add in a quiet operator environment that keeps you comfortable and productive, service points that make your routine maintenance quick and easy, and multiple Cat work tools that help you take on a variety of jobs, you simply won't find a better 90 ton machine.*

## **Contents**

Reliable and Productive.....	4
Fuel Efficient.....	6
Easy to Operate.....	8
Durable Structures.....	10
Durable Linkages.....	11
Versatile.....	12
Integrated Technologies.....	14
Safe Work Environment.....	16
Serviceable.....	17
Sustainable.....	18
Complete Customer Care.....	18
Specifications.....	19
Standard Equipment.....	32
Optional Equipment.....	33
Notes.....	34







## Reliable and Productive

Power to move your material with speed and precision

### Hydraulic Horsepower, a Cat Advantage

Hydraulic horsepower is the actual machine power available to do work through implements and work tools. It's much more than just the engine power under the hood – it's a core strength that differentiates Cat machines from other brands. In fact, pump and other system components work to put more power to the ground, in a highly controlled, user-friendly way. This means you will move more material in less time and keep more money in your pocket at the end of the day.

### Control Like No Other

The new Cat Adaptive Control System (ACS) valve optimizes performance by intelligently managing restrictions and flows to control machine motion, which means your operators will have the power and precision they need and expect. It opens slowly when your range of joystick lever movement is small and opens rapidly when movement is high. It smartly puts flow exactly where you need it when you need it, which leads to smoother operation, greater efficiency, and lower fuel consumption.



## **SmartBoom™**

### **Reduces Stress and Vibrations Transmitted to the Machine**

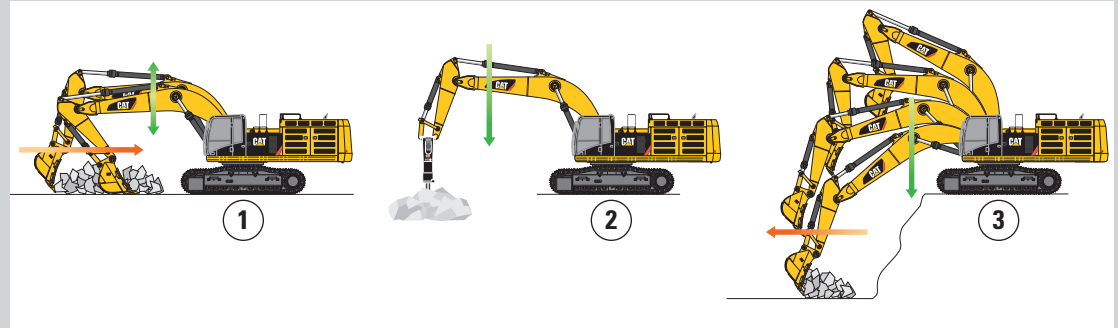

#### **Rock Scraping (1)**

Scraping rock and finishing work is easy and fast. SmartBoom simplifies the task and allows the operator to fully concentrate on the stick and bucket while the boom freely goes up and down without using pump flow.

#### **Hammer Work (2)**

It has never been this productive and operator-friendly. The front parts automatically follow the hammer while penetrating the rock. Blank shots or excessive force on the hammer are avoided, resulting in longer life for the hammer and machine. Similar advantages are applicable when using vibratory plates.

#### **Truck Loading (3)**

Loading trucks from a bench is more productive and fuel efficient as the return cycle is reduced while the boom down function does not require pump flow.

### **Auxiliary Hydraulics for Added Versatility**

Auxiliary hydraulics give you greater tool versatility so you can take on more work with just one machine, and there are several options from which you can choose. A quick coupler circuit, for example, will allow you to switch from one tool to another in a matter of minutes.

# Fuel Efficient

Engineered to lower your operating costs





The Cat C18 ACERT engine meets EU Stage IV emission standards and it does so without interrupting your job process. Simply turn the engine on and go to work. It will look for opportunities in your work cycle to regenerate itself, and it will give you plenty of power for the task at hand – all to help keep your owning and operating costs to an absolute minimum.

### **Fuel Savers That Add Up**

The 390F L features two power modes to help manage fuel consumption: standard power and economy. Two additional fuel-saving features are on-demand engine power and engine idle shutdown. On-demand engine power keeps speed low during light loading and idling; it automatically adjusts speed up when it senses a heavier load. Engine idle shutdown automatically shuts the engine off when idling for more than a specified amount of time that you set, which can save significant amounts of fuel and reduce emissions.

### **Biodiesel Not a Problem**

The C18 ACERT engine can run on biodiesel fuel up to B20 blended with ULSD. Just fill it up and go.

### **A Smart Design for Any Temperature**

The 390F L features a new side-by-side cooling system that allows you to put the machine to work in extremely hot and cold conditions. The system is completely separated from the engine compartment to reduce noise and heat. Plus it features easy-to-clean cores and a new variable-speed fan that reverses to blow out unwanted debris that may accumulate during your work day.

### **Proven Technology**

The right technologies fine-tuned for the right applications result in:

- **Improved Fluid Efficiency** – Up to 5% improvement over Stage IIIB products (including Diesel Exhaust Fluid consumption).
- **High Performance** across a variety of applications.
- **Enhanced Reliability** through commonality and simplicity of design.
- **Maximized Uptime and Reduced Cost** with world-class Cat dealer support.
- **Minimized Impact of Emission Systems** with no operator interaction required.
- **Durability** with long service life.
- **Better Fuel Economy** with minimized maintenance costs.
- **Same great power and response.**

# Easy to Operate

Comfort and convenience to keep you productive all day long





## Safe and Quiet Cab

The cab contributes to your comfort thanks to special viscous mounts and special roof lining and sealing, that limit vibration and unnecessary sound.

Operators will enjoy the quietness and comfort of the all-new cab that's insulated to reduce sound inside by 3 dB over the previous model.

## Excellent Ergonomics

Wide seats with air suspension and heat/cooling options, include a reclining back, upper and lower slide adjustments, and height and tilt angle adjustments to meet your needs for maximum comfort. The fully automatic climate control system keeps operators comfortable and productive all day long in either hot or cold weather. Storage spaces are located in the front, rear, and side consoles of the cab. A drink holder accommodates a large mug, and a shelf behind the seat stores large lunch or toolboxes. Power supply sockets are available for charging your electronic devices like an MP3 player, a cell phone, or even a tablet.

## Controls Just for You

The right and left joystick consoles can be adjusted to improve your comfort and productivity during the course of a day. The right joystick features a button that will reduce engine speed when you are not working to help save fuel. Touch it once and speed reduces; touch it again and speed increases for normal operation.

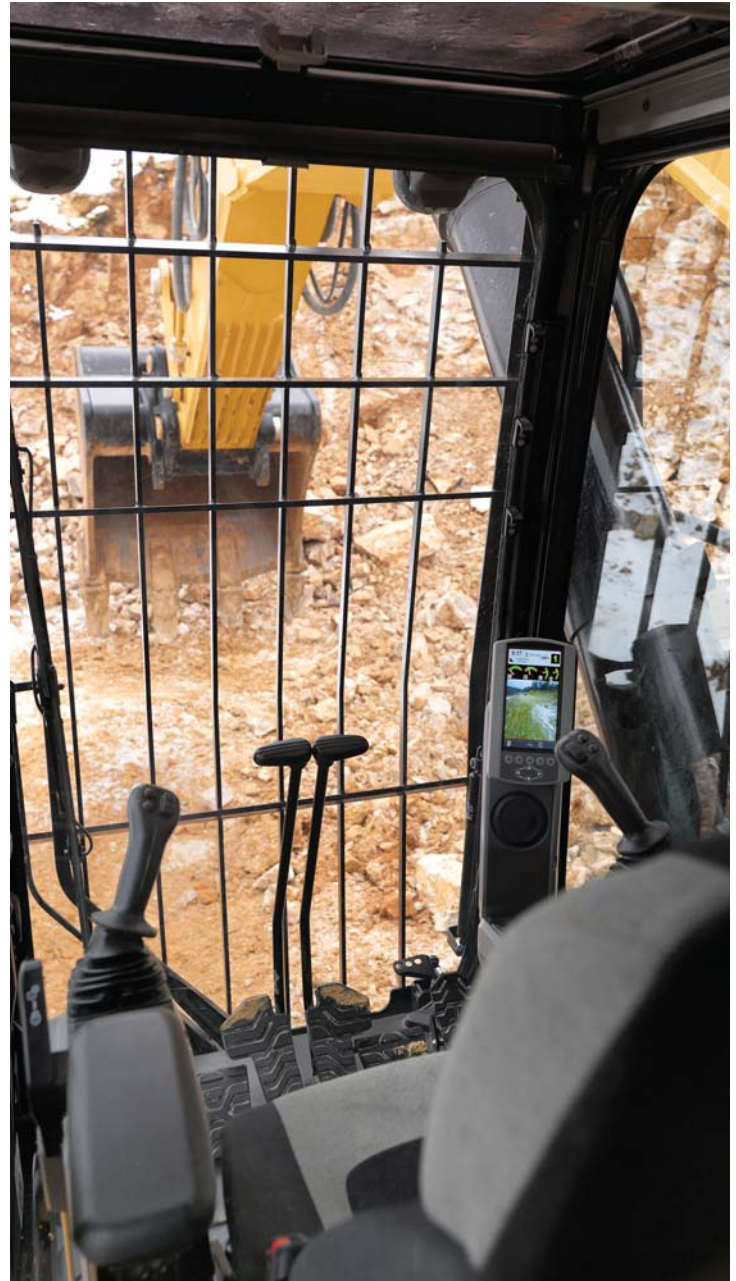

## Easy to Navigate Monitor

The new LCD monitor is easy to see and navigate. Not only can it memorize up to 10 different work tools, it's also programmable in up to 42 languages to meet today's diverse workforce. The monitor clearly displays critical information you need to operate efficiently and effectively. Plus it projects the image from the standard rearview camera to help you see what's going on around you so you can stay safely focused on the job at hand.

# Durable Structures

Designed to work in your tough, heavy-duty applications



## Stable Undercarriage

Long variable gauge undercarriage contributes significantly to its outstanding stability and durability, and it adjusts to reduce shipping width.

Track shoes, links, rollers, idlers, and final drives are all built with high-tensile-strength steel for long-term durability.

Cat GLT4 track link protects moving parts by keeping water, debris, and dust out and grease sealed in, which delivers longer wear life and reduced noise when traveling.

## Robust Frames

The 390F L is a robust, well-built machine designed to give you a very long service life. The upper frame includes special mountings made specifically to support the heavy-duty cab. It's also reinforced around areas that take on a lot of stress like the boom foot, skirt, and counterweight removal system.



Positive Pin Retention 2 (PPR2) prevents looseness of the track pin in the track link, reduces stress concentrations, and eliminates pin walking for increased service life.

Optional three-piece guide guards help maintain track alignment to improve your machine's overall performance – whether you're traveling on a flat, heavy bed of rock or a steep, wet field of mud.

## Great Weight

The pressed 12 400 kg fixed or removable counterweights are built with thick steel plates and reinforced fabrications to make them less susceptible to damage, and both have curved surfaces that match the machine's sleek, smooth appearance along with integrated housings to help protect the standard rearview camera.



## Durable Linkages

Options to take on your far-reaching or up-close tasks

### Built to Last

The 390F L is offered with a range of reach (R) and mass (ME) booms and sticks. Each is built with internal baffle plates and is stress relieved for added durability, and each undergoes ultrasound inspection to ensure quality and reliability. Large box-section structures with thick, multi-plate fabrications, castings, and forgings are used in high-stress areas such as the boom nose, boom foot, boom cylinder, and stick foot to improve durability. Also, the boom nose pin retention method is a captured flag design for enhanced durability.

### Booms, Sticks and Bucket Linkage for Any Job

An extra-long 10.0 m Reach boom (with 5.5 m or 4.4 m sticks) or an 8.4 m General Purpose boom (with 5.5 m, 4.4 m or 3.4 m sticks) offer you excellent all-around versatility for general excavation work like multipurpose digging and loading. A 7.25 m Mass boom (with 3.4 m or 2.92 m sticks) offer you enhanced performance in heavy-duty material like rock. They provide higher digging forces due to special boom and stick geometry, and bucket linkage and cylinders are built for greater durability.

Sticks are matched to the boom. Longer sticks are better when you need to dig deep or load trucks.

Bucket linkages with or without a lifting eye are available.

### Pins

All front linkage pins have thick chrome plating, giving them high wear resistance. Each pin diameter is made to distribute the shear and bending loads associated with the stick and to help ensure long pin, boom and stick life.

Talk to your Cat dealer to pick the best front linkage options for your applications.

# Versatile

Do more jobs with one machine



## Get the Most from One Machine

The Cat combination of machine and tool provides a total solution for just about any application. Work tools can be mounted either directly to the machine or to a quick coupler, making it fast and easy to release one work tool and pick up another.

## Change Jobs Quickly

Cat quick coupler brings the ability to quickly change attachments and switch from job to job. The CW dedicated coupler is the secure way to decrease downtime and increase job site flexibility and overall productivity.

Available tool control remembers pressures and flows for up to 10 tools. Simply toggle through the monitor, select the tool, and go to work for maximum efficiency.

## Dig, Rip and Load

A wide range of buckets dig everything from basic top soil to extreme, harsh material like ore and high quartzite granite. Rip through rock as an alternative to blasting in quarries. High-capacity buckets load trucks in a minimum number of passes for maximum productivity.

## Break, Demolish and Scrap

A hydraulic hammer ably equips your machine for breaking rock in quarries. It will also make taking down bridge pillars and heavily reinforced concrete on road demolition jobs no problem.

Multi-processor and pulverizer attachments make your 390F L ideal for demolition jobs and processing the resulting debris. Shears with 360° rotation mount to the machine for processing scrap steel and metal.

## Set Up Your Machine for Profitability

Your Cat dealer can install hydraulic kits to properly operate all Cat Work Tool attachments, maximizing the machine's uptime and your profit. All Cat Work Tool attachments are supported by the same Cat dealer network as your Cat machine.

1) General Duty (GD) 2) Heavy Duty (HD)  
3) Severe Duty (SD) 4) Extreme Duty (XD)

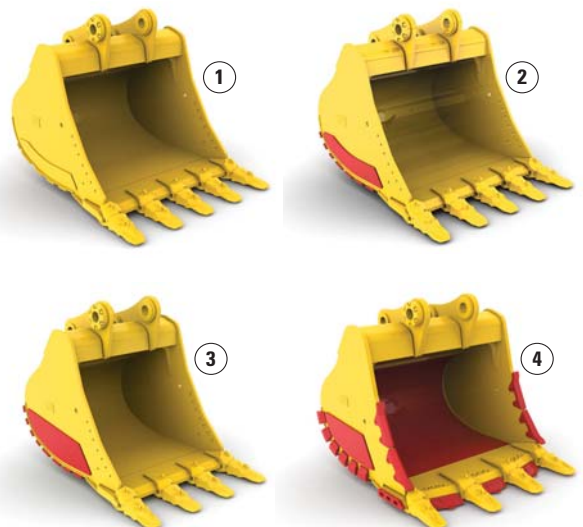



# Integrated Technologies

Monitor, manage, and enhance job site operations

Cat Connect makes smart use of technology and services to improve your job site efficiency. Using the data from technology-equipped machines, you'll get more information and insight into your equipment and operations than ever before.

Cat Connect technologies offer improvements in these key areas:



**Equipment Management** – increase uptime and reduce operating costs.



**Productivity** – monitor production and manage job site efficiency.



**Safety** – enhance job site awareness to keep your people and equipment safe.

## LINK Technologies

LINK technologies, like Product Link™, are deeply integrated into your machine and wirelessly communicates key information, including location, hours, fuel usage, idle time and event codes.

### Product Link/VisionLink®

Easy access to Product Link data via the online VisionLink user interface can help you see how your machine or fleet is performing. You can use this information to make timely, fact based decisions that can boost job site efficiency and productivity, and lower costs.



### **GRADE Technologies**

Grade technologies combine digital design data and in-cab guidance to help you reach target grade quickly and accurately, with minimal staking and checking. That means you'll be more productive, complete jobs faster, in fewer passes, using less fuel, at a lower cost.

### **Cat Grade Control Depth and Slope**

The integrated Cat Grade Control system delivers 2D bucket tip elevation guidance to the cab to help operators create precise planes and slopes. Real-time bucket tip elevation guidance on the standard cab monitor indicates how much to cut or fill. Fast response sensors deliver immediate feedback, while optional integrated joystick buttons help operators make quick adjustments to maintain grade. Built-in alerts can be set to warn the operator if the linkage or bucket approaches a predefined elevation or depth, such as when working in areas with low ceilings, or digging near water lines. Staking and checking is minimized, which reduces ground crews and enhances job site safety.

Works best in simple 2D applications, such as digging trenches and basements or grading steep embankments.

### **Cat AccuGrade™**

The dealer-installed AccuGrade system uses a dedicated monitor with a digital design plan for 3D bucket tip positioning and elevation guidance. AccuGrade indicates precisely where to work and how much to cut or fill – eliminating staking and checking.

Plug and play capability on the 390F L simplifies upgrading. Choose from satellite (GNSS) or total station (UTS) control for large projects with complex designs.



# Safe Work Environment

Features to help protect you day in and day out



## Great Views

Ample glass, coupled with the standard parallel wiper system, gives you excellent visibility out front and to the side.

Halogen lights provide plenty of illumination. Cab and boom lights can be programmed to stay on for up to 90 seconds after the engine has been turned off to help you safely exit the machine. Optional High Intensity Discharge (HID) lights are available for enhanced night-time visibility.

The standard rear vision camera greatly enhances visibility behind the machine to help the operator work more productively. A panoramic rearview is automatically displayed on the new multi-function monitor during reverse travel. As an option, a second display can be added, providing a dedicated full-time rearview of the job site.



## Secure Contact Points

Multiple large steps as well as hand and guard rails will get you into the cab as well as a leg up to the catwalks and compartments. Extended hand and guard rails allow you to safely climb to the upper deck. Anti-skid plates on the catwalks, the surface of the upper structure, and the top of the storage box area reduce your slipping hazards in all types of weather conditions. They can be removed for cleaning.

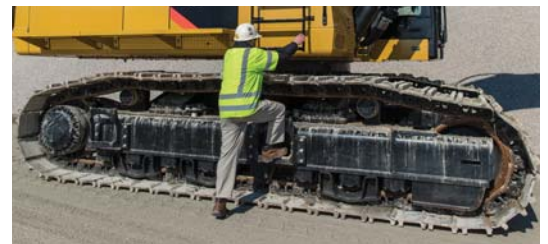



# Serviceable

Designed to make your maintenance quick and easy



## Convenient Access Built In

You can reach routine maintenance items like greasing points and a concentrated remote greasing block on boom foot from ground level.

Compartments feature wide service doors designed to help prevent debris entry, and they also securely latch in place to help make your service work simpler.

Machine's slip-resistant 500 mm wide catwalks stretch the length of the 390F L to provide safe access to major and grouped service points, such as fuel and oil filters, and fluid taps.

## Quick and Convenient Fluids Service

Oil sample and pressure ports provide easy checking of machine condition and are standard on every machine.

You can ensure fast, easy, and secure changing of engine and hydraulic oil with the QuickEvac™ option.

The fuel tank's drain cock makes it easy and simple for you to remove water and sediment during routine maintenance. Plus an integrated fuel level indicator pops up to help you reduce the possibility of fuel tank overfilling.

An optional fast fill port accessible from ground level can make refueling even easier and faster.

## A Smart Cooling Design

The 390F L features a new side-by-side cooling system with easy-to-clean cores and a new variable-speed fan that reverses to blow out unwanted debris that may accumulate during your work day.

## A Fresh Idea

Selecting ventilation inside the cab allows outside air to enter through the fresh air filter. The filter is conveniently located on the side of the cab to make it easy to reach and replace, and it is protected by a lockable door that can be opened with the engine key.



# Complete Customer Care

Unmatched support makes the difference

## Sustainable Generations ahead in every way

The 390F L is designed to compliment your business plan, reduce emissions and minimize the consumption of natural resources.

- The C18 ACERT engine meets EU Stage IV emission standards.
- The 390F L has the flexibility of running on either ultra-low-sulfur diesel (ULSD) fuel with 10 ppm of sulfur or less or biodiesel (up to B20) fuel blended with ULSD.
- An overfill indicator rises when the tank is full to help the operator avoid spilling.
- Quick fill ports with connectors ensure fast, easy, and secure changing of hydraulic oil.
- Major components are rebuildable, eliminating waste and saving money by giving the machine and/or major components a second life – and even a third life.
- Link technologies enable you to collect and analyze equipment and job site data so you can maximize productivity and reduce costs.
- The 390F L is an efficient, productive machine that's designed to conserve our natural resources for generations ahead.

### Worldwide Parts Availability

Cat dealers utilize a worldwide parts network to maximize your machines' uptime. Plus they can help you save money with Cat remanufactured components.

### Financial Options Just for You

Consider financing options and day-to-day operating costs. Look at dealer services that can be included in the machine's cost to yield lower owning and operating costs over time.

### What's Best for You Today...and Tomorrow

Repair, rebuild, or replace? Your Cat dealer can help you evaluate the cost involved so you can make the best choice for your business.



# 390F L Hydraulic Excavator Specifications

## Engine

Engine Model	Cat C18 ACERT
Power – ISO 14396 (metric)	405 kW (551 PS)
Power – ISO 9249 (metric)	391 kW (532 PS)
Bore	145 mm
Stroke	183 mm
Displacement	18.1 L

- The 390F L meets EU Stage IV emission standards.
- No engine power derating required below 2300 m altitude.
- Rating at 1,700 rpm (Implement).

## Operating Weights

Gradeability	30°/70%
Minimum – Reach Configuration	86 275 kg
Maximum – Mass Configuration	92 020 kg

## Drive

Maximum Travel Speed	4.5 km/h
Maximum Drawbar Pull	590 kN

## Track

Track Options	900 mm/750 mm/650 mm
Number of Shoes Each Side	51
Number of Track Rollers Each Side	9
Number of Carrier Rollers Each Side	3

## Swing Mechanism

Swing Speed	6.2 rpm
Swing Torque	260 kN·m

## Service Refill Capacities

Fuel Tank Capacity	1240 L
Cooling System	74 L
Engine Oil	60 L
Swing Drive (each)	19 L
Final Drive (each)	21 L
Hydraulic System Oil Capacity (including tank)	997 L
Hydraulic Tank Oil	813 L
DEF Tank	48 L

## Hydraulic System

Main System – Maximum Flow (total)	
Implement	952 L/min
Travel	1064 L/min
Swing System – Maximum Flow	
No swing pump	
Maximum Pressure	
Equipment – Normal	35 000 kPa
Travel	35 000 kPa
Swing	26 000 kPa
Pilot System	
Maximum Flow	67 L/min
Maximum Pressure	4.0-4.4 MPa
Boom Cylinder	
Bore	210 mm
Stroke	1967 mm
Stick Cylinder	
Bore	220 mm
Stroke	2262 mm
HB2 – Family Bucket Cylinder	
Bore	200 mm
Stroke	1451 mm
JC – Family Bucket Cylinder	
Bore	220 mm
Stroke	1586 mm

## Sound Performance

Operator Sound Pressure Level ISO 6396	74 dB(A)
Exterior Sound Power Level ISO 6395	109 dB(A)*

\* Per European Union Directive 2000/14/EC as amended by 2005/88/EC.

- When properly installed and maintained, the cab offered by Caterpillar, when tested with doors and windows closed according to ANSI/SAE J1166 OCT98, meets OSHA and MSHA requirements for operator sound exposure limits in effect at time of manufacture.
- Hearing protection may be needed when operating with an open operator station and cab (when not properly maintained or doors/windows open) for extended periods or in a noisy environment.

## Standards

Brakes	SAE J1026/APR90
Cab/FOGS	SAE J1356/FEB88 ISO 10262
DEF	ISO 22241

# 390F L Hydraulic Excavator Specifications

## Dimensions

All dimensions are approximate.

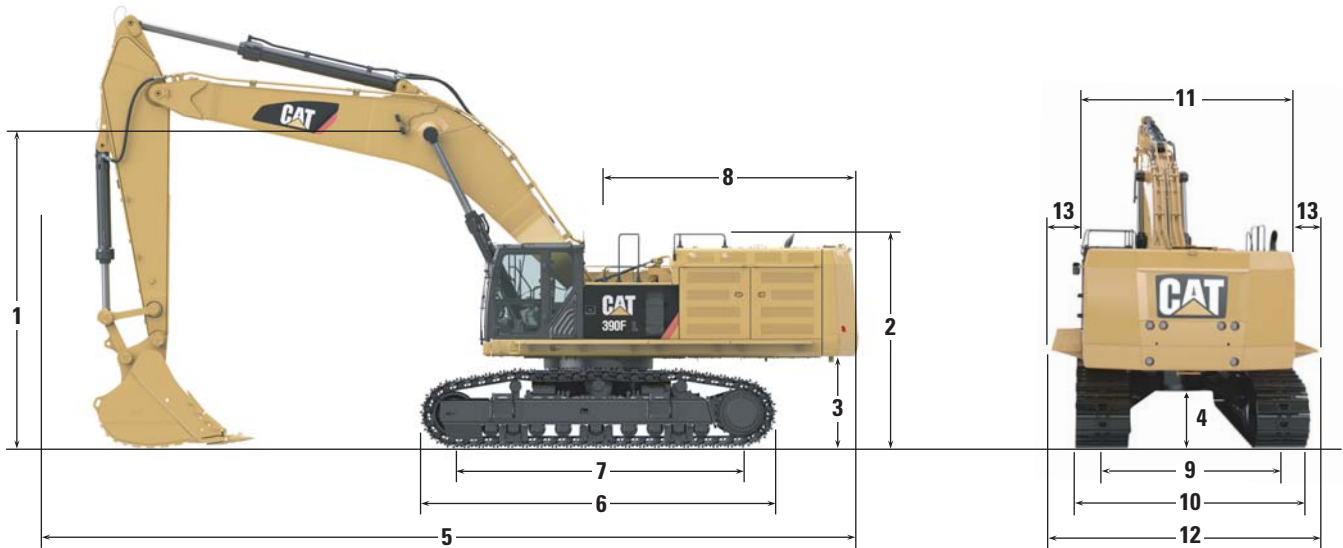

Boom Options		Reach Boom 10.0 m		GP Boom 8.4 m		Mass Boom 7.25 m		
Stick Options		R5.5 m	R4.4 m	R5.5 m	R4.4 m	G3.4 m	M3.4 m	M2.92 m
<b>1</b> Height – with boom/stick installed	mm	5490	5070	5840	5290	5160	5310	4890
<b>2</b> Guardrail Height	mm	3830	3830	3830	3830	3830	3830	3830
<b>3</b> Counterweight Clearance	mm	1640	1640	1640	1640	1640	1640	1640
<b>4</b> Ground Clearance	mm	900	900	900	900	900	900	900
<b>5</b> Length – with boom/stick installed	mm	16 290	16 330	14 500	14 690	14 720	13 550	13 690
<b>6</b> Track Length	mm	6358	6358	6358	6358	6358	6358	6358
<b>7</b> Length to Center of Rollers	mm	5120	5120	5120	5120	5120	5120	5120
<b>8</b> Tail Swing Radius	mm	4700	4700	4700	4700	4700	4700	4700
<b>9</b> Track Gauge – retracted	mm	2750	2750	2750	2750	2750	2750	2750
Track Gauge – extended	mm	3510	3510	3510	3510	3510	3510	3510
<b>10</b> Undercarriage Width – without steps								
650 mm Shoes	mm	4160	4160	4160	4160	4160	4160	4160
750 mm Shoes	mm	4260	4260	4260	4260	4260	4260	4260
900 mm Shoes	mm	4410	4410	4410	4410	4410	4410	4410
Undercarriage Width – including steps								
650 mm Shoes	mm	4450	4450	4450	4450	4450	4450	4450
750 mm Shoes	mm	4450	4450	4450	4450	4450	4450	4450
900 mm Shoes	mm	4450	4450	4450	4450	4450	4450	4450
<b>11</b> Upperframe Width – without walkways	mm	3470	3470	3470	3470	3470	3470	3470
<b>12</b> Upperframe Width – with walkways	mm	4510	4510	4510	4510	4510	4510	4510
<b>13</b> Walkway Width (each)	mm	520	520	520	520	520	520	520
<b>Bucket Type</b>		GD	GD	GD	GD	SD	SDV	SDV
<b>Bucket Capacity</b>	m <sup>3</sup>	3.9	3.9	4.6	4.6	4.6	6.0	6.0
<b>Bucket Tip Radius</b>	mm	2424	2424	2319	2319	2319	2505	2505

Dimensions may vary depending on bucket selection.

# 390F L Hydraulic Excavator Specifications

## Working Ranges

All dimensions are approximate.

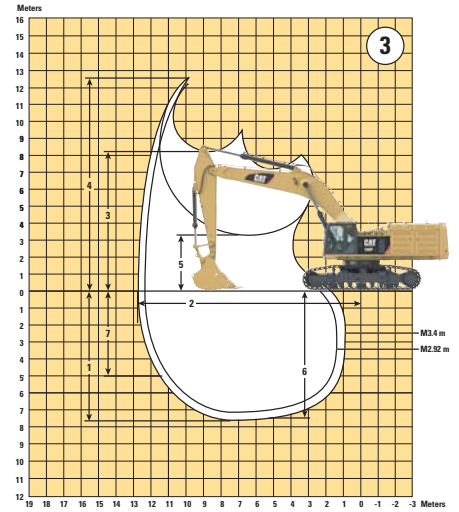
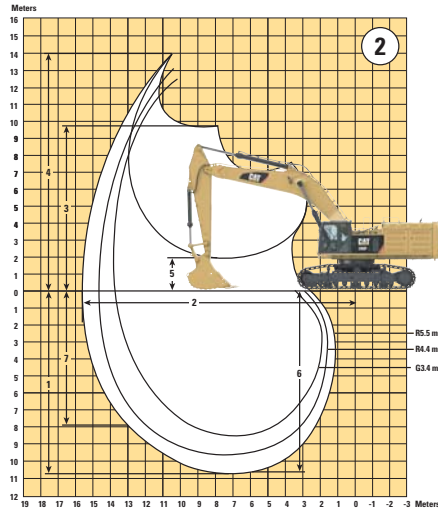
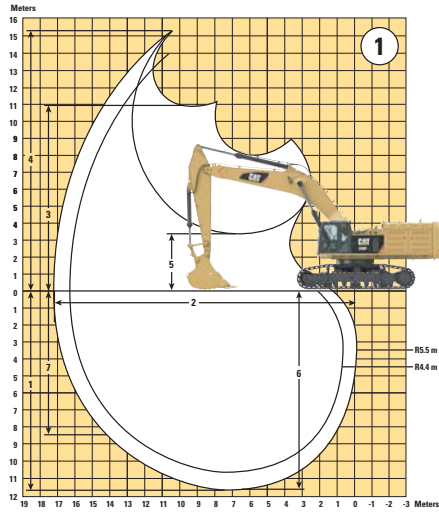

## Boom Options

①

Reach Boom  
10.0 m

②

GP Boom  
8.4 m

③

Mass Boom  
7.25 m

Stick Options	①		②			③		
	R5.5 m	R4.4 m	R5.5 m	R4.4 m	G3.4 m	M3.4 m	M2.92 m	
1 Maximum Digging Depth	mm	11 800	10 700	10 750	9650	8680	7640	7160
2 Maximum Reach at Ground Line	mm	17 250	16 230	15 730	14 690	13 910	12 690	12 240
3 Maximum Loading Height	mm	10 960	10 530	9730	9280	9100	8210	7990
4 Maximum Cutting Height	mm	15 180	14 750	14 000	13 540	13 470	12 580	12 360
5 Minimum Loading Height	mm	3320	4420	1950	3050	4030	3210	3680
6 Maximum Depth Cut for 2240 mm Level Bottom	mm	11 700	10 590	10 650	9540	8550	7510	7020
7 Maximum Vertical Wall Digging Depth	mm	8380	7380	7860	6850	6180	5090	4690
Bucket Digging Force (ISO)	kN	364.8	363.3	364.8	363.3	470.9	470.9	470.4
Stick Digging Force (ISO)	kN	235.9	276.0	235.9	276.0	325.5	325.5	356.3
<b>Bucket Type</b>		GD	GD	GD	GD	SD	SDV	SDV
<b>Bucket Capacity</b>	m <sup>3</sup>	3.9	3.9	4.6	4.6	4.6	6.0	6.0
<b>Bucket Tip Radius</b>	mm	2424	2424	2319	2319	2319	2505	2505

Dimensions may vary depending on bucket selection.

# 390F L Hydraulic Excavator Specifications

## Operating Weights and Ground Pressures

Boom	Stick	Bucket	900 mm Shoe		750 mm Shoe		650 mm Shoe	
			Weight	Ground Pressure	Weight	Ground Pressure	Weight	Ground Pressure
R10.0 m	R5.5 m	3.9 m <sup>3</sup>	89 827 kg	88.1 kPa	88 780 kg	104.5 kPa	87 906 kg	119.4 kPa
R10.0 m	R4.4 m	3.9 m <sup>3</sup>	89 319 kg	87.6 kPa	88 272 kg	103.9 kPa	87 398 kg	118.7 kPa
GP8.4 m	R5.5 m	4.6 m <sup>3</sup>	88 704 kg	87.0 kPa	87 657 kg	103.2 kPa	86 783 kg	117.8 kPa
GP8.4 m	R4.4 m	4.6 m <sup>3</sup>	88 196 kg	86.5 kPa	87 149 kg	102.6 kPa	86 275 kg	117.2 kPa
GP8.4 m	G3.4 m	4.6 m <sup>3</sup>	90 603 kg	88.9 kPa	89 556 kg	105.4 kPa	88 682 kg	120.4 kPa
M7.25 m	M3.4 m	6.0 m <sup>3</sup>	92 022 kg	90.3 kPa	90 975 kg	107.1 kPa	90 101 kg	122.4 kPa
M7.25 m	M2.92 m	6.0 m <sup>3</sup>	91 764 kg	90.0 kPa	90 717 kg	106.8 kPa	89 843 kg	122.0 kPa

## Major Components Weights

Base Machine (with counterweight, without front linkage, without bucket)*	<b>kg</b>
650 mm Tracks	66 739
750 mm Tracks	67 613
900 mm Tracks	68 660
Two Boom Cylinders	1804
Counterweight	
Removal Type	12 400
Non-removal Type	12 400
Boom (includes lines, pins, stick cylinder)	
Reach Boom – 10.0 m	9839
General Purpose Boom – 8.4 m	8392
Mass Boom – 7.25 m	8437
Stick (includes lines, pins, bucket cylinder, linkage)	
R5.5 m	5430
R4.4 m	4922
G3.4 m	5186
M3.4 m	5447
M2.92 m	5189
Bucket	
3.9 m <sup>3</sup> GD	4094
4.6 m <sup>3</sup> GD	4418
6.0 m <sup>3</sup> SDV	7674

\*Base machine includes 75 kg operator weight and 90% fuel weight, and undercarriage with center guard.

# 390F L Hydraulic Excavator Specifications

## Reach Boom Lift Capacities – Counterweight: 12.4 mt – Without Bucket

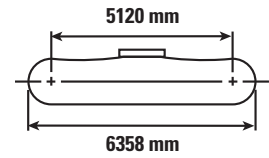
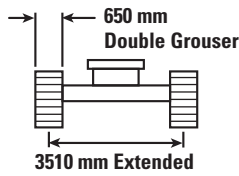
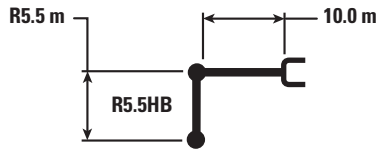

		1500 mm		3000 mm		4500 mm		6000 mm		7500 mm		mm		
12 000 mm	kg											*9600	*9600	11 830
10 500 mm	kg											*9300	*9300	12 880
9000 mm	kg											*9150	9050	13 680
7500 mm	kg											*9150	8150	14 280
6000 mm	kg									*19 800	*19 800	*9250	7500	14 690
4500 mm	kg							*28 600	*28 600	*22 050	22 000	*9500	7050	14 950
3000 mm	kg							*20 000	*20 000	*24 050	20 300	*9900	6800	15 050
1500 mm	kg							*15 650	*15 650	*25 400	18 950	*10 450	6700	14 990
0 mm	kg							*16 950	*16 950	*25 950	18 150	10 650	6700	14 790
-1500 mm	kg					*11 250	*11 250	*20 650	*20 650	*25 800	17 700	10 950	6900	14 420
-3000 mm	kg			*12 200	*12 200	*16 750	*16 750	*26 100	24 700	*24 950	17 500	11 550	7300	13 880
-4500 mm	kg			*17 800	*17 800	*22 900	*22 900	*28 300	24 950	*23 400	17 600	*11 800	7950	13 140
-6000 mm	kg			*24 050	*24 050	*30 050	*30 050	*25 150	*25 150	*21 100	17 850	*11 500	9050	12 170
-7500 mm	kg					*24 250	*24 250	*20 850	*20 850	*17 700	*17 700	*10 850	*10 850	10 910
-9000 mm	kg							*14 850	*14 850	*12 650	*12 650	*9250	*9250	9230

		9000 mm		10 500 mm		12 000 mm		13 500 mm		15 000 mm		mm		
12 000 mm	kg											*9600	*9600	11 830
10 500 mm	kg					*12 100	12 000					*9300	*9300	12 880
9000 mm	kg			*13 350	*13 350	*12 550	11 850	*10 050	9300			*9150	9050	13 680
7500 mm	kg			*14 000	*14 000	*12 900	11 500	*12 100	9150			*9150	8150	14 280
6000 mm	kg	*16 850	*16 850	*14 850	13 900	*13 400	11 100	*12 350	8900			*9250	7500	14 690
4500 mm	kg	*18 250	16 750	*15 750	13 200	*14 000	10 600	*12 700	8600			*9500	7050	14 950
3000 mm	kg	*19 550	15 650	*16 600	12 450	*14 550	10 100	12 800	8300	*10 250	6850	*9900	6800	15 050
1500 mm	kg	*20 550	14 750	*17 300	11 850	14 950	9650	12 450	8000			*10 450	6700	14 990
0 mm	kg	*21 100	14 100	*17 700	11 350	14 600	9300	12 200	7750			10 650	6700	14 790
-1500 mm	kg	*21 150	13 650	17 400	11 000	14 300	9050	12 050	7600			10 950	6900	14 420
-3000 mm	kg	*20 650	13 450	17 200	10 800	14 200	8950	12 000	7550			11 550	7300	13 880
-4500 mm	kg	*19 550	13 450	*16 450	10 800	*13 850	8950					*11 800	7950	13 140
-6000 mm	kg	*17 700	13 650	*14 800	10 950	*11 900	9200					*11 500	9050	12 170
-7500 mm	kg	*14 800	14 050	*11 800	11 400							*10 850	*10 850	10 910
-9000 mm	kg	*9800	*9800									*9250	*9250	9230



ISO 10567



\*Indicates that the load is limited by hydraulic lifting capacity rather than tipping load. The above loads are in compliance with hydraulic excavator lift capacity standard ISO 10567:2007. They do not exceed 87% of hydraulic lifting capacity or 75% of tipping load. Weight of all lifting accessories must be deducted from the above lifting capacities. Lifting capacities are based on the machine standing on a firm, uniform supporting surface. The use of a work tool attachment point to handle/lift objects, could affect the machine lift performance.

Lift capacity stays with ±5% for all available track shoes.

Always refer to the appropriate Operation and Maintenance Manual for specific product information.

# 390F L Hydraulic Excavator Specifications

## Reach Boom Lift Capacities – Counterweight: 12.4 mt – Without Bucket

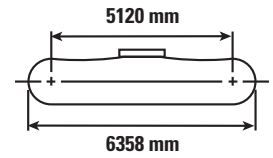
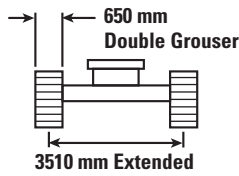
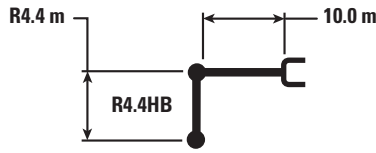

Reach Boom Lift Configuration	3000 mm		4500 mm		6000 mm		7500 mm		Reach Boom Lift Configuration		mm
12 000 mm kg									*12 950	*12 950	10 510
10 500 mm kg									*12 450	12 200	11 680
9000 mm kg									*12 250	10 500	12 560
7500 mm kg									*12 250	9400	13 210
6000 mm kg					*28 100	*28 100	*21 950	*21 950	*12 450	8600	13 660
4500 mm kg							*24 050	21 100	12 400	8100	13 940
3000 mm kg							*25 700	19 650	12 050	7800	14 040
1500 mm kg							*26 450	18 700	11 950	7700	13 980
0 mm kg					*13 250	*13 250	*26 400	18 200	12 100	7750	13 760
-1500 mm kg					*20 150	*20 150	*25 600	18 000	12 550	8050	13 370
-3000 mm kg			*18 050	*18 050	*28 450	25 550	*24 200	18 050	*13 050	8600	12 780
-4500 mm kg			*26 900	*26 900	*25 800	*25 800	*22 100	18 250	*12 800	9500	11 970
-6000 mm kg			*24 450	*24 450	*22 000	*22 000	*19 100	18 700	*12 150	11 100	10 900
-7500 mm kg					*16 750	*16 750	*14 650	*14 650	*10 750	*10 750	9460

Reach Boom Lift Configuration	9000 mm		10 500 mm		12 000 mm		13 500 mm		Reach Boom Lift Configuration		mm
12 000 mm kg			*13 000	*13 000					*12 950	*12 950	10 510
10 500 mm kg			*14 450	*14 450					*12 450	12 200	11 680
9000 mm kg			*14 750	14 750	*13 800	11 500			*12 250	10 500	12 560
7500 mm kg	*17 150	*17 150	*15 300	14 250	*14 050	11 300			*12 250	9400	13 210
6000 mm kg	*18 400	17 350	*16 100	13 650	*14 500	10 900	13 300	8800	*12 450	8600	13 660
4500 mm kg	*19 700	16 300	*16 900	12 950	*14 950	10 500	13 050	8600	12 400	8100	13 940
3000 mm kg	*20 750	15 350	*17 600	12 350	*15 350	10 100	12 800	8350	12 050	7800	14 040
1500 mm kg	*21 450	14 650	*18 050	11 850	15 000	9750	12 600	8100	11 950	7700	13 980
0 mm kg	*21 650	14 150	17 850	11 450	14 750	9450	12 400	7950	12 100	7750	13 760
-1500 mm kg	*21 300	13 900	17 650	11 200	14 550	9300			12 550	8050	13 370
-3000 mm kg	*20 350	13 850	*17 200	11 150	*14 500	9300			*13 050	8600	12 780
-4500 mm kg	*18 750	14 000	*15 750	11 250					*12 800	9500	11 970
-6000 mm kg	*16 150	14 300	*13 100	11 650					*12 150	11 100	10 900
-7500 mm kg	*11 850	*11 850							*10 750	*10 750	9460



ISO 10567



\*Indicates that the load is limited by hydraulic lifting capacity rather than tipping load. The above loads are in compliance with hydraulic excavator lift capacity standard ISO 10567:2007. They do not exceed 87% of hydraulic lifting capacity or 75% of tipping load. Weight of all lifting accessories must be deducted from the above lifting capacities. Lifting capacities are based on the machine standing on a firm, uniform supporting surface. The use of a work tool attachment point to handle/lift objects, could affect the machine lift performance.

Lift capacity stays with ±5% for all available track shoes.

Always refer to the appropriate Operation and Maintenance Manual for specific product information.



# 390F L Hydraulic Excavator Specifications

## GP Boom Lift Capacities – Counterweight: 12.4 mt – Without Bucket

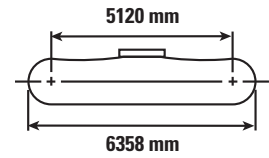
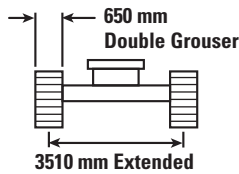
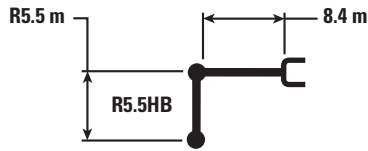

		1500 mm		3000 mm		4500 mm		6000 mm		7500 mm		mm		
														mm
12 000 mm	kg											*8950	*8950	9840
10 500 mm	kg											*8350	*8350	11 080
9000 mm	kg											*8050	*8050	12 010
7500 mm	kg											*7950	*7950	12 680
6000 mm	kg											*7950	*7950	13 150
4500 mm	kg							*26 650	*26 650	*21 800	*21 800	*8100	*8100	13 440
3000 mm	kg							*31 000	*31 000	*24 350	22 750	*8450	*8450	13 550
1500 mm	kg							*34 200	29 800	*26 450	21 500	*8900	8850	13 490
0 mm	kg					*18 900	*18 900	*35 800	28 500	*27 750	20 600	*9600	8950	13 260
-1500 mm	kg			*14 150	*14 150	*23 150	*23 150	*35 900	27 800	*28 150	20 000	*10 550	9250	12 840
-3000 mm	kg	*16 300	*16 300	*20 100	*20 100	*29 350	*29 350	*34 700	27 600	*27 550	19 750	*12 050	9950	12 230
-4500 mm	kg	*22 150	*22 150	*27 000	*27 000	*37 700	*37 700	*32 150	27 700	*25 850	19 750	*14 300	11 050	11 390
-6000 mm	kg			*35 500	*35 500	*35 100	*35 100	*28 000	*28 000	*22 650	20 000	*14 450	13 050	10 250
-7500 mm	kg					*26 500	*26 500	*21 600	*21 600	*17 150	*17 150	*13 200	*13 200	8710

		9000 mm		10 500 mm		12 000 mm		13 500 mm		15 000 mm		mm		
														mm
12 000 mm	kg											*8950	*8950	9840
10 500 mm	kg			*10 850	*10 850							*8350	*8350	11 080
9000 mm	kg			*12 900	*12 900	*8050	*8050					*8050	*8050	12 010
7500 mm	kg			*14 300	*14 300	*11 400	*11 400					*7950	*7950	12 680
6000 mm	kg	*17 300	*17 300	*15 850	14 750	*13 400	11 650					*7950	*7950	13 150
4500 mm	kg	*18 800	18 200	*16 800	14 200	*15 250	11 350					*8100	*8100	13 440
3000 mm	kg	*20 400	17 300	*17 800	13 650	*15 950	11 000	*8850	*8850			*8450	*8450	13 550
1500 mm	kg	*21 750	16 500	*18 650	13 100	15 950	10 650					*8900	8850	13 490
0 mm	kg	*22 700	15 850	19 150	12 700	15 650	10 400					*9600	8950	13 260
-1500 mm	kg	*23 000	15 400	18 800	12 350	15 450	10 200					*10 550	9250	12 840
-3000 mm	kg	*22 550	15 200	18 650	12 250	*15 350	10 200					*12 050	9950	12 230
-4500 mm	kg	*21 150	15 200	*17 250	12 300							*14 300	11 050	11 390
-6000 mm	kg	*18 250	15 450									*14 450	13 050	10 250
-7500 mm	kg											*13 200	*13 200	8710



ISO 10567



\*Indicates that the load is limited by hydraulic lifting capacity rather than tipping load. The above loads are in compliance with hydraulic excavator lift capacity standard ISO 10567:2007. They do not exceed 87% of hydraulic lifting capacity or 75% of tipping load. Weight of all lifting accessories must be deducted from the above lifting capacities. Lifting capacities are based on the machine standing on a firm, uniform supporting surface. The use of a work tool attachment point to handle/lift objects, could affect the machine lift performance.









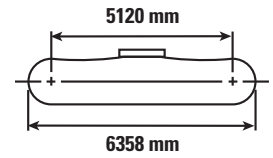
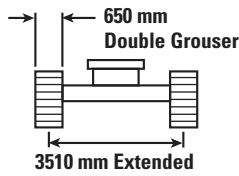
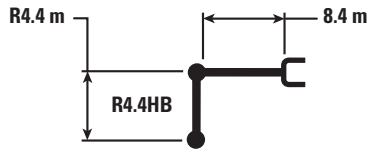

Lift capacity stays with ±5% for all available track shoes.

Always refer to the appropriate Operation and Maintenance Manual for specific product information.











# 390F L Hydraulic Excavator Specifications

## GP Boom Lift Capacities – Counterweight: 12.4 mt – Without Bucket



		1500 mm		3000 mm		4500 mm		6000 mm				mm
												
10 500 mm	kg									*11 350	*11 350	9800
9000 mm	kg									*10 900	*10 900	10 830
7500 mm	kg									*10 700	*10 700	11 580
6000 mm	kg									*10 750	*10 750	12 090
4500 mm	kg							*30 400	*30 400	*11 050	10 650	12 400
3000 mm	kg							*34 100	30 700	*11 500	10 250	12 520
1500 mm	kg							*36 200	29 150	*12 200	10 150	12 460
0 mm	kg							*36 500	28 400	*13 300	10 350	12 210
-1500 mm	kg					*24 050	*24 050	*35 450	28 100	*14 850	10 850	11 760
-3000 mm	kg			*23 500	*23 500	*33 450	*33 450	*33 200	28 150	*16 450	11 800	11 080
-4500 mm	kg			*33 150	*33 150	*36 200	*36 200	*29 500	28 500	*16 050	13 500	10 140
-6000 mm	kg					*28 650	*28 650	*23 900	*23 900	*14 950	*14 950	8840

		7500 mm		9000 mm		10 500 mm		12 000 mm				mm
												
10 500 mm	kg			*15 400	*15 400					*11 350	*11 350	9800
9000 mm	kg			*17 300	*17 300	*13 350	*13 350			*10 900	*10 900	10 830
7500 mm	kg			*18 000	*18 000	*16 850	14 800			*10 700	*10 700	11 580
6000 mm	kg	*21 850	*21 850	*19 200	18 600	*17 450	14 450	*11 750	11 450	*10 750	*10 750	12 090
4500 mm	kg	*24 200	23 500	*20 600	17 800	*18 200	14 000	*15 150	11 250	*11 050	10 650	12 400
3000 mm	kg	*26 400	22 200	*21 900	17 050	*19 000	13 550	16 300	11 000	*11 500	10 250	12 520
1500 mm	kg	*28 000	21 200	*22 950	16 400	*19 550	13 100	16 000	10 750	*12 200	10 150	12 460
0 mm	kg	*28 650	20 550	*23 450	15 900	19 250	12 800	15 850	10 600	*13 300	10 350	12 210
-1500 mm	kg	*28 300	20 200	*23 200	15 600	19 050	12 600			*14 850	10 850	11 760
-3000 mm	kg	*26 850	20 150	*22 050	15 550	*18 050	12 600			*16 450	11 800	11 080
-4500 mm	kg	*24 150	20 350	*19 600	15 750					*16 050	13 500	10 140
-6000 mm	kg	*19 400	*19 400							*14 950	*14 950	8840



ISO 10567



\*Indicates that the load is limited by hydraulic lifting capacity rather than tipping load. The above loads are in compliance with hydraulic excavator lift capacity standard ISO 10567:2007. They do not exceed 87% of hydraulic lifting capacity or 75% of tipping load. Weight of all lifting accessories must be deducted from the above lifting capacities. Lifting capacities are based on the machine standing on a firm, uniform supporting surface. The use of a work tool attachment point to handle/lift objects, could affect the machine lift performance.









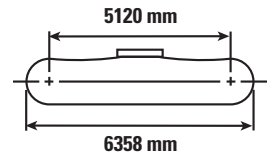
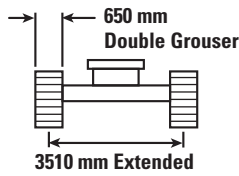
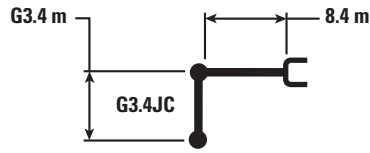



Lift capacity stays with ±5% for all available track shoes.

Always refer to the appropriate Operation and Maintenance Manual for specific product information.

# 390F L Hydraulic Excavator Specifications

## GP Boom Lift Capacities – Counterweight: 12.4 mt – Without Bucket



		4500 mm		6000 mm		7500 mm		9000 mm		10 500 mm				mm
														
10 500 mm	kg											*15 450	*15 450	8740
9000 mm	kg							*18 750	18 750			*14 500	*14 500	9890
7500 mm	kg					*21 450	*21 450	*19 250	18 350	*17 150	14 050	*14 100	13 550	10 710
6000 mm	kg			*28 700	*28 700	*23 350	*23 350	*20 200	17 750	*18 250	13 800	*14 050	12 200	11 260
4500 mm	kg			*32 800	31 050	*25 500	22 400	*21 400	17 050	*18 800	13 400	*14 250	11 400	11 590
3000 mm	kg					*27 300	21 250	*22 450	16 350	*19 300	13 000	*14 800	10 950	11 720
1500 mm	kg					*28 250	20 450	*23 100	15 800	19 150	12 650	*15 650	10 900	11 650
0 mm	kg			*33 250	27 850	*28 200	20 000	*23 100	15 450	18 900	12 450	16 850	11 150	11 380
-1500 mm	kg	*21 450	*21 450	*33 300	27 900	*27 150	19 850	*22 300	15 350	*18 250	12 400	*17 050	11 850	10 900
-3000 mm	kg	*35 400	*35 400	*30 150	28 150	*24 900	20 000	*20 350	15 450			*16 600	13 200	10 170
-4500 mm	kg	*29 450	*29 450	*25 450	*25 450	*21 000	20 400	*16 050	15 900			*15 500	*15 500	9130
-6000 mm	kg			*18 000	*18 000	*13 500	*13 500					*13 000	*13 000	7610



ISO 10567



\*Indicates that the load is limited by hydraulic lifting capacity rather than tipping load. The above loads are in compliance with hydraulic excavator lift capacity standard ISO 10567:2007. They do not exceed 87% of hydraulic lifting capacity or 75% of tipping load. Weight of all lifting accessories must be deducted from the above lifting capacities. Lifting capacities are based on the machine standing on a firm, uniform supporting surface. The use of a work tool attachment point to handle/lift objects, could affect the machine lift performance.

Lift capacity stays with ±5% for all available track shoes.

Always refer to the appropriate Operation and Maintenance Manual for specific product information.

# 390F L Hydraulic Excavator Specifications

## Mass Boom Lift Capacities – Counterweight: 12.4 mt – Without Bucket

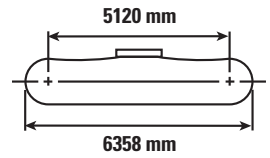
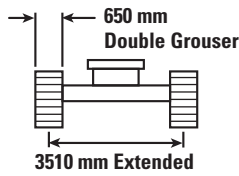
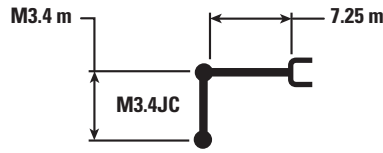

		3000 mm		4500 mm		6000 mm		7500 mm		9000 mm		mm		
10 500 mm	kg											*17 250	*17 250	6970
9000 mm	kg							*21 550	*21 550			*15 800	*15 800	8380
7500 mm	kg							*23 200	*23 200	*18 850	18 400	*15 200	*15 200	9330
6000 mm	kg					*29 000	*29 000	*24 600	24 400	*21 850	18 050	*15 100	*15 100	9960
4500 mm	kg			*45 150	*45 150	*32 650	*32 650	*26 450	23 350	*22 700	17 500	*15 450	13 950	10 330
3000 mm	kg					*35 800	31 100	*28 100	22 250	*23 500	16 950	*16 200	13 350	10 480
1500 mm	kg					*37 200	29 750	*29 050	21 400	*23 850	16 400	*17 450	13 300	10 400
0 mm	kg			*27 900	*27 900	*36 650	29 100	*28 900	20 900	*23 450	16 100	*19 400	13 700	10 100
-1500 mm	kg	*23 500	*23 500	*41 650	*41 650	*34 200	28 900	*27 250	20 700	*21 650	16 000	*19 450	14 800	9550
-3000 mm	kg	*38 650	*38 650	*36 350	*36 350	*29 650	29 150	*23 550	20 850			*18 450	17 050	8700
-4500 mm	kg			*26 650	*26 650	*22 050	*22 050					*15 900	*15 900	7450



ISO 10567



\*Indicates that the load is limited by hydraulic lifting capacity rather than tipping load. The above loads are in compliance with hydraulic excavator lift capacity standard ISO 10567:2007. They do not exceed 87% of hydraulic lifting capacity or 75% of tipping load. Weight of all lifting accessories must be deducted from the above lifting capacities. Lifting capacities are based on the machine standing on a firm, uniform supporting surface. The use of a work tool attachment point to handle/lift objects, could affect the machine lift performance.

Lift capacity stays with ±5% for all available track shoes.

Always refer to the appropriate Operation and Maintenance Manual for specific product information.

# 390F L Hydraulic Excavator Specifications

## Mass Boom Lift Capacities – Counterweight: 12.4 mt – Without Bucket

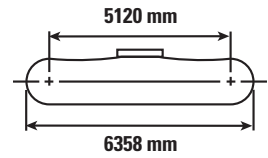
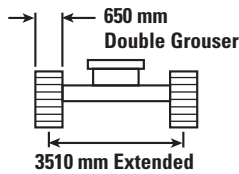
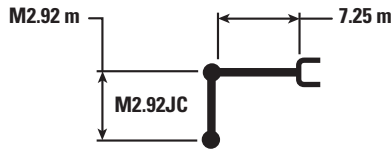

		3000 mm		4500 mm		6000 mm		7500 mm		9000 mm		mm		
10 500 mm	kg											*21 000	*21 000	6290
9000 mm	kg							*22 700	*22 700			*19 000	*19 000	7820
7500 mm	kg							*24 400	*24 400			*18 200	*18 200	8830
6000 mm	kg			*39 800	*39 800	*30 550	*30 550	*25 650	24 200	*22 750	17 950	*18 150	16 350	9500
4500 mm	kg					*34 050	32 600	*27 350	23 150	*23 400	17 450	*18 550	15 000	9890
3000 mm	kg					*36 700	30 800	*28 800	22 200	*23 950	16 950	*19 550	14 350	10 040
1500 mm	kg					*37 450	29 650	*29 400	21 450	*24 100	16 500	*21 150	14 250	9960
0 mm	kg			*26 100	*26 100	*36 200	29 200	*28 800	21 000	*23 250	16 250	*20 900	14 800	9640
-1500 mm	kg			*40 200	*40 200	*33 100	29 150	*26 600	20 900	*20 550	16 300	*20 250	16 150	9060
-3000 mm	kg			*33 150	*33 150	*27 850	*27 850	*21 950	21 250			*18 800	*18 800	8170
-4500 mm	kg					*18 750	*18 750					*15 650	*15 650	6740



ISO 10567



\*Indicates that the load is limited by hydraulic lifting capacity rather than tipping load. The above loads are in compliance with hydraulic excavator lift capacity standard ISO 10567:2007. They do not exceed 87% of hydraulic lifting capacity or 75% of tipping load. Weight of all lifting accessories must be deducted from the above lifting capacities. Lifting capacities are based on the machine standing on a firm, uniform supporting surface. The use of a work tool attachment point to handle/lift objects, could affect the machine lift performance.

Lift capacity stays with ±5% for all available track shoes.

Always refer to the appropriate Operation and Maintenance Manual for specific product information.

# 390F L Hydraulic Excavator Specifications

## Bucket Specifications and Compatibility

	Linkage	Width	Capacity	Weight	Fill	Reach Boom		GP Boom			Mass Boom	
		mm	m <sup>3</sup>	kg	%	R5.5 m	R4.4 m	R5.5 m	R4.4 m	G3.4 m	M3.4 m	M2.92 m
<b>Without Quick Coupler</b>												
General Duty (GD)	HB2	1100	2.2	2856	100%	⊖	●	●	●	–	–	–
	HB2	1350	2.9	3187	100%	◇	⊖	⊙	●	–	–	–
	HB2	1650	3.7	3650	100%	⊗	◇	○	⊙	–	–	–
	HB2	1900	4.3	3923	100%	⊗	⊗	○	⊖	–	–	–
	HB2	2000	4.6	4032	100%	⊗	⊗	◇	○	–	–	–
Heavy Duty (HD)	JC	1750	4.1	4799	100%	–	–	–	–	⊖	●	●
Severe Duty (SD)	JC	2300	5.4	6809	90%	–	–	–	–	◇	⊖	⊙
	JC	2400	5.7	7015	90%	–	–	–	–	◇	⊖	⊙
	JC	2500	6.0	7342	90%	–	–	–	–	⊗	○	⊖
Extreme Duty (XD)	JC	2200	5.0	6557	90%	–	–	–	–	◇	⊙	●
	JC	2300	5.4	7733	90%	–	–	–	–	⊗	○	⊖
	JC	2400	5.7	7968	90%	–	–	–	–	◇	○	⊖
Maximum dynamic load pin on (payload + bucket)					kg	6350	7535	8850	10 420	11 430	14 600	15 850
<b>With Quick Coupler (CW-70)</b>												
Severe Duty (SD)	JC	2300	5.4	6559	90%	–	–	–	–	⊗	○	⊖
	JC	2400	5.7	6765	90%	–	–	–	–	⊗	○	⊖
Maximum dynamic load with CW coupler (payload + bucket)					kg	4930	6115	7430	9000	10 010	13 180	14 430

### Maximum Material Density

- 2100 kg/m<sup>3</sup> or greater
- ⊙ 1800 kg/m<sup>3</sup> or greater
- ⊖ 1500 kg/m<sup>3</sup> or less
- 1200 kg/m<sup>3</sup> or less
- ◇ 900 kg/m<sup>3</sup> or less
- ⊗ Not Recommended

The above figures are based on maximum recommended dynamic working weights with front linkage fully extended at ground line with bucket curled. They do not exceed a stability ratio of 1.25.

Capacity based on ISO 7451.

Bucket weights include HD Long tips.

Caterpillar recommends using appropriate work tools to maximize the value customers receive from our products. Use of work tools, including buckets, which are outside of Caterpillar's recommendations or specifications for weight, dimensions, flows, pressures, etc. may result in less-than-optimal performance, including but not limited to reductions in production, stability, reliability, and component durability. Improper use of a work tool resulting in sweeping, prying, twisting and/or catching of heavy loads will reduce the life of the boom and stick.

# 390F L Hydraulic Excavator Specifications

## Work Tool Offering Guide\*

Boom Type	Reach Boom – 10.0 m		GP Boom – 8.4 m			Mass Boom – 7.25 m	
	R5.5 m	R4.4 m	R5.5 m	R4.4 m	R3.4 m	M3.4 m	M2.92 m
Stick Size							
Multi-Processor	MP40	MP40	MP40	MP40	MP40	MP40	MP40
Mobile Scrap and Demolition Shear	S385C**	S385C**	S385C**	S385C**	S385C**	S385C**	S385C**
CW Quick Coupler	CW70	CW70	CW70	CW70	CW70	CW70	CW70
Rippers	These work tools are available for the 390F L. Consult your Cat dealer for proper match.						

\*Matches are dependent on excavator configurations. Consult your Cat dealer for proper work tool match.

\*\*Pin on only.

# 390F L Standard Equipment

## Standard Equipment

Standard equipment may vary. Consult your Cat dealer for details.

### CAB

- Parallel wiper and washer
- Mirrors
- Pressurized operator station with positive filtration
- Laminated glass front upper window and tempered other windows
- Sliding upper door window (left-hand cab door)
- Removable lower windshield with in cab storage bracket
- Openable skylight
- Interior:
  - Glass-breaking safety hammer
  - Coat hook
  - Beverage holder
  - Literature holder
  - Interior lighting
  - AM/FM radio mounting (DIN size)
  - Two 12V stereo speakers
  - Storage shelf suitable for lunch or toolbox
  - Power supply with 12V, two power outlets (10 amp)
  - Thumb wheel modulation joystick for use with combined auxiliary control
  - Sun screen
  - Air conditioner, heater and defroster with climate control
- Seat:
  - Seatbelt, 76 mm
  - Adjustable armrest
  - Height adjustable joystick consoles
  - Neutral lever (lock out) for all controls
  - Travel control pedals with removable hand levers
  - Capability of installing two additional pedals
  - Two speed travel
  - Floor mat, washable
- Monitor:
  - Clock
  - Video ready
  - Color LCD display with warning, filter/fluid change, and working hour information
  - Language display (full graphic and full color display)
  - Machine condition, error code and tool mode setting information
  - Start-up level check for engine oil, engine coolant and hydraulic oil
  - Warning, filter/fluid change and working hour information
  - Fuel consumption meter

### ELECTRICAL

- 80 amp alternator
- Circuit breaker
- Battery, standard

### ENGINE

- C18 ACERT diesel engine
- EU Stage IV emission standards
- 2300 m altitude capability with no derate
- Up to B20 Biodiesel capable
- Automatic engine speed control
- Electric priming pump with switch
- Water separator in fuel line including water level sensor and indicator
- Economy and standard power modes
- Air cleaner
- Side-by-side cooling system
- Steel wall between engine and pump compartment
- Primary filter with water separator and water separator indicator switch
- Starting kit, cold weather, –18° C
- Primary fuel filter
- Secondary fuel filter
- Tertiary fuel filter
- Quick drains, engine and hydraulic oil (QuickEvac)

### HYDRAULIC SYSTEM

- Reverse swing dampening valve
- Automatic swing parking brake
- High-performance hydraulic return filter
- Regeneration circuit for boom and stick
- Capability of installing additional auxiliary circuits
- Reversing cooling fan
- Bio oil capable
- SmartBoom

### LIGHTS

- Cab and boom lights with time delay
- Exterior lights integrated into storage box

### UNDERCARRIAGE/UPPERFRAME

- Grease Lubricated Track with PPR2 GLT4, resin seal
- Heavy duty track roller and idler
- Track motor guards
- Towing eye on base frame
- Heavy duty bottom guards on upperframe
- Counterweight with lifting eyes (fixed or removable)

### SAFETY AND SECURITY

- Cat one key security system
- Door locks
- Cap locks on fuel and hydraulic tanks
- Lockable external tool/storage box
- Signaling/warning horn
- Secondary engine shutoff switch
- Mirrors
- Rear window for emergency exit
- Rear vision camera
- Capability to connect a beacon
- Bolt on FOGS capability
- Service walkways
- Safety hammer for breaking cab glass

### INTEGRATED TECHNOLOGIES

- Product Link
- Rear vision camera



## Optional Equipment

Optional equipment may vary. Consult your Cat dealer for details.

### FRONT LINKAGE

- Reach boom 10.0 m (with or without BLCV/SLCV):
  - R5.5HB2 (with or without CGC)
  - R4.4HB2 (with or without CGC)
  - HB2 – family bucket linkage (with or without lifting eye)
- General Purpose boom 8.4 m (with or without BLCV/SLCV):
  - R5.5HB2 (with or without CGC)
  - R4.4HB2 (with or without CGC)
  - G3.4JC
  - HB2 – family bucket linkage (with or without lifting eye)
  - JC – family bucket linkage (with or without lifting eye)
- Mass boom 7.25 m (with or without BLCV/SLCV):
  - M3.4JC
  - M2.92JC
  - JC – family bucket linkage (with or without lifting eye)

### TRACK

- Double grouser, Heavy Duty, 650 mm
- Double grouser, Heavy Duty, 750 mm
- Double grouser, Heavy Duty, 900 mm

### GUARDS

- FOGS (Falling Object Guard System) including overhead and windshield guards
- TOP guard including overhead guards
- Track guiding guards:
  - Full length, 2 pieces
  - Segmented, 3 pieces
  - Center section

### LIGHTS

- Cab working lights, halogen
- Cab working lights, HID
- Boom working lights, halogen
- Boom working lights, HID

### CAB

- Seat:
  - Adjustable high-back, heated seat with air suspension
  - Adjustable high-back, heated and ventilated seat with air suspension
- Cab front rain protector
- Windshield:
  - 70-30 split, sliding
  - One-piece, fixed
- Straight travel pedal

### HYDRAULIC SYSTEM

- Boom and stick lowering control devices with SmartBoom
- Counterweight removal device
- HP hydraulic lines for boom and stick
- MP hydraulic lines for boom and stick
- QC hydraulic lines for boom and stick
- CW dedicated QC control

### ELECTRICAL

- Cold weather starting package, 240V
- Travel alarm
- Electric refueling pump

### INTEGRATED TECHNOLOGIES

- Cat Grade Control depth and slope

### ENGINE

- Fast fill port for fuel





For more complete information on Cat products, dealer services, and industry solutions, visit us on the web at [www.cat.com](http://www.cat.com)

© 2015 Caterpillar  
All rights reserved

Materials and specifications are subject to change without notice. Featured machines in photos may include additional equipment. See your Cat dealer for available options.

CAT, CATERPILLAR, SAFETY.CAT.COM, their respective logos, "Caterpillar Yellow" and the "Power Edge" trade dress, as well as corporate and product identity used herein, are trademarks of Caterpillar and may not be used without permission.

VisionLink is a trademark of Trimble Navigation Limited, registered in the United States and in other countries.

AEHQ7250-02 (08-2015)  
Replaces AEHQ7250-01  
(Europe)

