

PHOTO TO COME

Cat[®] 249D3

COMPACT TRACK LOADER

PRELIMINARY

FEATURES:

The Cat[®] 249D3 Compact Track Loader, with its vertical lift design, delivers extended reach and lift height for quick and easy truck loading. Its standard, suspended undercarriage system provides superior traction, flotation, stability and speed to work in a wide range of applications and underfoot conditions. The 249D3 features the following:

- **Industry leading sealed and pressurized cab option** provides a cleaner and quieter operating environment with excellent work tool visibility.
- **Available high-back, heated, air ride seat with seat mounted adjustable joystick controls** makes the D3 Series the industry leader in operator comfort.
- **High performance power train** provides maximum performance and production capability through the Electronic Torque Management system, standard two speed travel and an electronic hand/foot throttle with decel pedal capability.
- **High Flow hydraulic system** is available for applications that demand maximum hydraulic work tool performance.
- **Broader range of applications** with an optional wide bar-tread track that delivers better traction in snow, more flotation and less ground disturbance.

- **Electronically controlled Cat C2.2 engine** provides high horsepower and torque while meeting U.S. EPA Tier 4 Final and EU Stage IIIB* emission standards.
- **Cat "Intelligent Leveling" system** provides industry leading technology, integration, and available features such as dual direction self level, work tool return to dig, and work tool positioner.
- **Standard fully independent torsion axle suspension** combined with the optional Speed Sensitive Ride Control system improves operation on rough terrain, enabling better load retention, increased productivity and greater operator comfort.
- **Maximize machine capability and control** with the available Advanced Display providing on-screen adjustments for implement response, hystat response and creep control. Also features multi-language functionality with customizable layouts, security system and rearview camera.
- **Ground level access** to all daily service and routine maintenance points helps reduce machine downtime for greater productivity.
- **Broad range of performance matched Cat Work Tools** make the Cat Compact Track Loader the most versatile machine on the job site.

*Stage IIIB engines comply with the transition provisions of the EU non-road emission regulation.

Specifications

Engine

Engine Model	Cat C2.2 CRDI	
Gross Power SAE J1995	50.1 kW	67.1 hp
Net Power SAE 1349	49.1 kW	65.8 hp
Net Power ISO 9249	49.6 kW	66.5 hp
Peak Torque at 1,500 rpm SAE J1995	208 N-m	153 lbf-ft
Displacement	2.2 L	134.3 in ³
Stroke	100 mm	3.9 in
Bore	84 mm	3.3 in

Weights*

Operating Weight	3486 kg	7,685 lb
------------------	---------	----------

*Operating Weight, Operating Specifications and Dimensions all based on 75 kg (165 lb) operator, all fluids, 1730 mm (68 in) low profile bucket, 320 mm (12.6 in) tracks, standard flow hydraulics, C0 cab (OROPS, static seat), 850 CCA battery, manual quick coupler, no self level and no optional counterweights (unless otherwise noted).

Power Train

Travel Speed (Forward or Reverse)		
One Speed	8.1 km/h	5 mph
Two Speed	12.2 km/h	7.6 mph

Hydraulic System

Hydraulic Flow – Standard:		
Loader Hydraulic Pressure	23 000 kPa	3,336 psi
Loader Hydraulic Flow	69 L/min	18 gal/min
Hydraulic Power (calculated)	26.5 kW	35.5 hp
Hydraulic Flow – High Flow:		
Loader Hydraulic Pressure	23 000 kPa	3,336 psi
Loader Hydraulic Flow	99 L/min	26 gal/min
Hydraulic Power (calculated)	38.0 kW	50.9 hp



249D3 Compact Track Loader

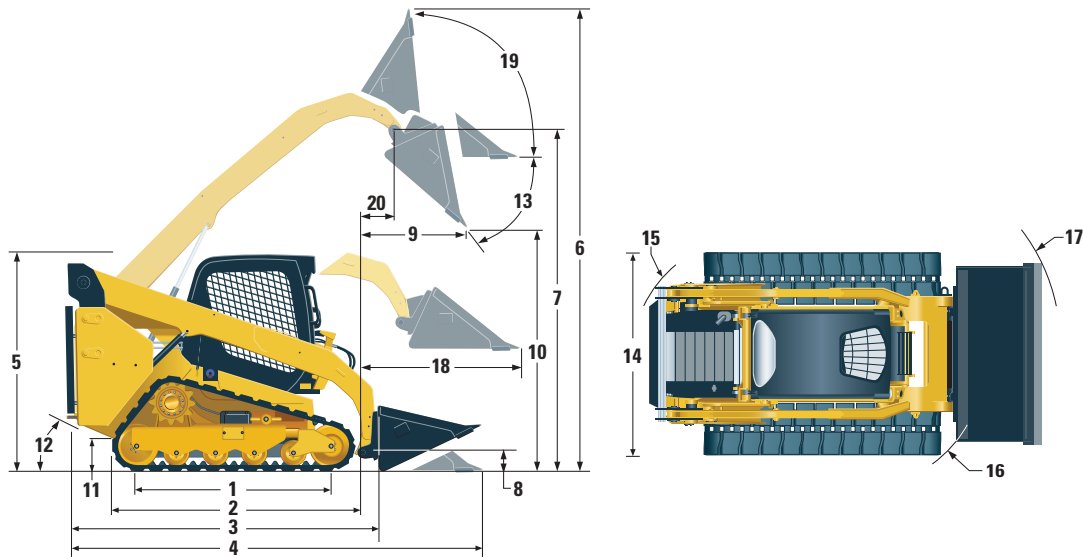

Dimensions*

1 Length of Track on Ground	1384 mm	54.5 in	12 Departure Angle	34.5°
2 Overall Length of Track	1808 mm	71.2 in	13 Maximum Dump Angle	48°
3 Length without Bucket	2523 mm	99.3 in	14 Vehicle Width (320 mm/12.6 in tracks)	1676 mm 66.0 in
4 Length with Bucket on Ground	3233 mm	127.3 in	Vehicle Width (400 mm/15.7 in tracks)	1756 mm 69.1 in
5 Height to Top of Cab	2039 mm	80.3 in	15 Turning Radius from Center – Machine Rear	1458 mm 57.4 in
6 Maximum Overall Height	3831 mm	150.8 in	16 Turning Radius from Center – Coupler	1160 mm 45.7 in
7 Bucket Pin Height at Maximum Lift	3002 mm	118.2 in	17 Turning Radius from Center – Bucket	2060 mm 81.1 in
8 Bucket Pin Height at Carry Position	219 mm	8.6 in	18 Maximum Reach with Arms Parallel to Ground	1317 mm 51.8 in
9 Reach at Maximum Lift and Dump	727 mm	28.6 in	19 Rack Back Angle at Maximum Height	87.5°
10 Clearance at Maximum Lift and Dump	2253 mm	88.7 in	20 Bucket Pin Reach at Maximum Lift	311 mm 12.2 in
11 Ground Clearance	194 mm	7.6 in		

Operating Specifications*

Rated Operating Capacity:		
35% Tipping Load	730 kg	1,610 lb
50% Tipping Load	1044 kg	2,300 lb
Rated Operating Capacity with Optional Counterweight		
Tipping Load	2087 kg	4,600 lb
Breakout Force, Tilt Cylinder	1772 kg	3,907 lb
Ground Contact Area (320 mm/12.6 in track)	0.89 m ²	1,373 in ²
Ground Contact Area (400 mm/15.7 in track)	1.11 m ²	1,716 in ²
Ground Pressure (320 mm/12.6 in track)	38.6 kPa	5.6 psi
Ground Pressure (400 mm/15.7 in track)	31.7 kPa	4.6 psi

Cab

ROPS	ISO 3471:2008
FOPS	ISO 3449:2005 Level I

Service Refill Capacities

Cooling System	12 L	3.2 gal
Engine Crankcase	10 L	2.6 gal
Fuel Tank	57 L	15.1 gal
Hydraulic System	45 L	11.9 gal
Hydraulic Tank	34 L	9.0 gal

Noise Level

Inside Cab**	83 dB(A)
Outside Cab***	103 dB(A)

- Cab and Rollover Protective Structures (ROPS) are standard in North America and Europe.

**The declared dynamic operator sound pressure levels per ISO 6396:2008. The measurements were conducted with the cab doors and windows closed and at 70% of the maximum engine cooling fan speed. The sound level may vary at different engine cooling fan speeds.

***The labeled sound power level for the CE marked configurations when measured according to the test procedure and conditions specified in 2000/14/EC.

Air Conditioning System (if equipped)

The air conditioning system on this machine contains the fluorinated greenhouse gas refrigerant R134a (Global Warming Potential = 1430). The system contains 0.81 kg of refrigerant which has a CO₂ equivalent of 1.158 metric tonnes.

MANDATORY EQUIPMENT

- Hydraulics, Standard or High Flow
- Quick Coupler, Mechanical or Powered
- High Visibility Seat Belt, 50 mm (2 in) or 75 mm (3 in)
- EU Preparation Package (Europe only)
- Steel Imbed Rubber Track – 320 mm (12.6 in) Block Tread or 400 mm (15.7 in) Bar Tread
- Dual Flange Front Idler/Single Flange Rear Idler

PERFORMANCE PACKAGES

- Performance Package H1: *Standard Flow Hydraulics (No Self Level)*
- Performance Package H2: *Standard Flow Hydraulics, Dual Direction Electronic Self Level (Raise and Lower), Work Tool Return to Dig, Work Tool Positioner, and Electronic Snubbing (Raise and Lower)*
- Performance Package H3: *High Flow Hydraulics, Dual Direction Electronic Self Level (Raise and Lower), Work Tool Return to Dig, Work Tool Positioner, and Electronic Snubbing (Raise and Lower)*

STANDARD EQUIPMENT

ELECTRICAL

- 12 volt Electrical System
- 80 ampere Alternator
- Ignition Key Start/Stop Switch
- Lights: *Gauge Backlighting, Two Rear Tail Lights, Two Adjustable Front and Rear Halogen Lights, Dome Light*
- Backup Alarm
- Heavy Duty Battery, 850 CCA

OPERATOR ENVIRONMENT

- Gauges: *Fuel Level, Hour Meter*
- Operator Warning System Indicators: *Air Filter Restriction, Alternator Output, Armrest Raised/Operator Out of Seat, Engine Coolant Temperature, Engine Oil Pressure, Glow Plug Activation, Hydraulic Filter Restriction, Hydraulic Oil Temperature, Park Brake Engaged*
- Adjustable Vinyl Seat
- Fold In Ergonomic Contoured Armrest
- Control Interlock System, when operator leaves seat or armrest raised: *Hydraulic System Disables, Hydrostatic Transmission Disables, Parking Brake Engages*
- ROPS Cab, Open, Tilt Up
- FOPS, Level I
- Top and Rear Windows
- Floor Mat
- Interior Rearview Mirror
- 12 volt Electric Socket
- Horn
- Hand (Dial) Throttle, Electronic
- Adjustable Joystick Controls
- Anti-theft Security System with 6-button Keypad
- Storage Compartment with Netting

COMFORT PACKAGES

- Open ROPS (C0): *Static Seat (No Foot Throttle, Headliner, Heater or Door)*
- Open ROPS (C1): *Foot Throttle, Headliner, Cup Holder, and choice of Seat (Mechanical Suspension or High Back, Heated, Air Ride Seat) (No Heater or Door)*
- Enclosed ROPS with Heater (C2): *Foot Throttle, Headliner, Heater and Defroster, Side Windows, Cup Holder, Radio Ready, choice of Seat (Mechanical Suspension or High Back, Heated, Air Ride Seat) and Door (Glass or Polycarbonate)*
- Enclosed ROPS with A/C (C3): *C2 + Air Conditioner*

POWER TRAIN

- Cat C2.2, Turbo Diesel Engine, Meeting Tier 4 Final and Stage IIIB* emission standards
- Air Cleaner, Dual Element, Radial Seal
- S-O-SSM Sampling Valve, Hydraulic Oil
- Filters, Cartridge-type, Hydraulic
- Filters, Canister-type, Fuel and Water Separator
- ATAAC/Radiator/Hydraulic Oil Cooler (side-by-side)
- Spring Applied, Hydraulically Released Parking Brakes
- Hydrostatic Transmission, One Speed Travel
- Suspension – Independent Torsion Axles (4)

*Stage IIIB engines comply with the transition provisions of the EU non-road emission regulation.

OTHER

- Engine Enclosure, Lockable
- Extended Life Antifreeze, -36° C (-33° F)
- Machine Tie Down Points (6)
- Support, Lift Arm
- Hydraulic Oil Level Sight Gauge
- Radiator Coolant Level Sight Gauge
- Radiator, Expansion Bottle
- Cat ToughGuardTM Hose
- Auxiliary, Hydraulics, Continuous Flow
- Heavy Duty, Flat Faced Quick Disconnects with Integrated Pressure Release
- Split D-Ring to Route Work Tool Hoses Along Side of Left Lift Arm
- Electrical Outlet, Beacon
- Belly Pan Cleanout
- Variable Speed Demand Fan
- Product LinkTM PL240, Cellular

249D3 Compact Track Loader

OPTIONAL EQUIPMENT

- Hand-Foot Style Controls
- External Counterweights
- Beacon, Rotating
- Engine Block Heater – 120V
- Oil, Hydraulic, Cold Operation
- Paint, Custom
- Product Link PL641, Cellular
- Ride Control
- Advanced Display with Rearview Camera: *Full Color, 127 mm (5 in) LCD screen, Advanced Multi-operator Security System, On-screen Adjustments for Implement Response, Hystat Response, and Creep Control. (Standard Equipment in Europe Only)*
- Work Tool Return to Dig and Work Tool Positioner
- Bluetooth® Radio with Microphone (AM/FM/Weather Band Receiver with USB and Auxiliary Input Jack)

For more complete information on Cat products, dealer services, and industry solutions, visit us on the web at www.cat.com

© 2019 Caterpillar
All rights reserved

Materials and specifications are subject to change without notice. Featured machines in photos may include additional equipment. See your Cat dealer for available options.

CAT, CATERPILLAR, LET'S DO THE WORK, their respective logos, "Caterpillar Yellow," the "Power Edge" and Cat "Modern Hex" trade dress as well as corporate and product identity used herein, are trademarks of Caterpillar and may not be used without permission.

AEHQ8196 (05-2019)
(Am North, EU, APD, ANZP)

