

990H

Wheel Loader



Engine

Engine Model	Cat® C27 ACERT™	
Gross Power	512 kW	687 hp
Net Power	468 kW	627 hp

Buckets

Bucket Capacities	8.4-9.2 m ³	(11-12 yd ³)
-------------------	------------------------	--------------------------

Operating Specifications

Rated Payload	15 tonnes	16.5 tons
Operating Weight	77 842 kg	171,642 lb

990H Wheel Loader

State-of-the-art design and superior quality allow you to maximize productivity.

Power Train

- ✓ The Cat® C27 ACERT™ engine is U.S. EPA Tier 3/EU Stage IIIa compliant and with MEUI, an air-to-air aftercooler, axle-shaft brakes, impeller clutch torque converter and planetary electronic power shift transmission forms a responsive, fuel efficient power train. **pg. 4**

Cooling System

- ✓ The Next Generation Modular Cooling System with Air-to-Air Aftercooling System has been added to the 990H to help meet emissions requirements and improve efficiency, serviceability, visibility and sound levels. **pg. 6**

Structures

The integrated structural components of the 990H provide a stable, well-balanced system. The full box-section rear frame, four plate loader tower, Z-bar loader linkage and solid steel lift arms work together to enable a loaded bucket to move smoothly through the lift and dump cycle. **pg. 7**

Application Truck Match

Increased performance and good pass matching make the 990H a versatile performer. **pg. 13**

High Lift Arrangement Optional Attachment

- ✓ Provides more dump clearance and reach than the standard arrangement and increases productivity. **pg. 14**



Efficiency through Technology.

The 990H Wheel Loader equipped with the standard lift arrangement is the ideal match for the 45-64 tonnes (50-70 ton) truck and is leading the way into the future with proven, advanced technology. With the High Lift Arrangement as an attachment, the 990H can also load the 90 tonnes (100 ton) class truck. This machine will provide the lowest cost per ton in its size class.

Buckets and Bucket Match

A wide selection of ruggedly designed buckets along with a variety of edge and tip options allow you to match the machine to the job. **pg. 8**

Operator's Station

✓ Designed to maximize operator productivity with the STIC™ control system, Computerized Monitoring System and Comfort Series seat with trainer seat and lapbelt and many other features that enhance productivity through operator comfort. **pg. 10**

Hydraulic System

✓ Increased high-pressure hydraulics give you fast lift and dump speeds. Two separate hydraulic systems and load-sensing steering are the invisible force behind the muscle and flexibility of the 990H. **pg. 12**

Serviceability

Rear access stairs, large engine doors, convenient service platform with large doors and bolt-on panels make service on the 990H quick and easy. **pg. 15**

Complete Customer Support

Your Cat dealer offers a wide range of services that help you operate longer with lower costs. **pg. 16**



✓ *New Feature*

Power Train

The 990H power train components give you the dependable performance expected from Cat Wheel Loaders.

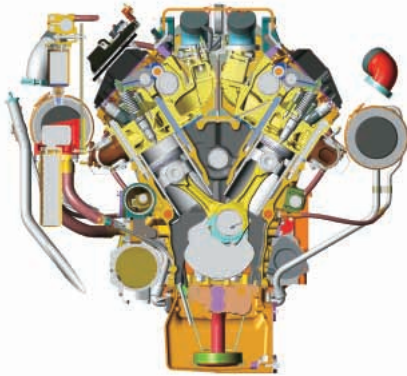

Cat C27 ACERT Engine. The C27 is a 27 L (1,648 in³) displacement, 12 cylinder, “V” configured engine with Mechanical Electronic Unit Injector (MEUI) fuel system and Electronic Control Module (ECM) that delivers power and efficiency in the most demanding applications. Benefits of the C27 include:

- ADEM™ IV
- Automatic altitude deration
- Elevated low idle
- Cold weather starting mode
- Acceleration delay on start-up to reduce engine wear
- Advanced diagnostic capabilities
- Automatic control of ether aid
- 500 hour oil change interval with CH-4 oil and new larger oil pan
- Dry-type air cleaner with primary and secondary elements
- Engine/torque divider module isolation mounted to the main frame to reduce machine vibration and structure noise
- Monotherm pistons

Aftercooler. Lowers inlet charge temperature and reduces thermal stresses that can cause premature wear of pistons, rings and liners.

High Injection Pressures. Independent of engine speed, decreases smoke and emissions while improving response.

Variable Injection Timing and Duration.

Improves fuel efficiency, cold starting and decreases smoke and emissions.

Injection Rate Shaping. Reduces emissions and reduces engine noise.

Fewer Mechanical Parts.

Improve reliability.

C27 Electronic Control. Provides many benefits:

- Automatic altitude derate
- Elevated low idle
- Cold mode start for improved cold weather starting
- Acceleration delay on startup to reduce engine wear
- Advanced diagnostic capabilities
- ADEM IV
- Automatic control of ether aid

Oil-Cooled Pistons and Full-Length, Water-Cooled Cylinder Liners.

Provide maximum heat transfer for longer component life.

Engine Oil Cooler. Maintains optimum oil temperature for proper cooling and lubrication. Engine cooling is provided by the Next Generation Modular Radiator. Hydrostatic fan drive gives the standard cooling package 110° F ambient capability.

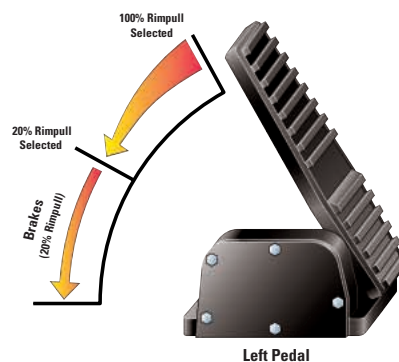

Impeller Clutch Torque Converter (ICTC).

The converter allows the operator maximum flexibility in modulating rimpull. The first inch of travel of the left brake pedal is used to modulate rimpull from 100 percent (pedal at rest position) to 20 percent of maximum (pedal depressed about 25 mm [1 in]). Once 20 percent of maximum rimpull is achieved, the brake is applied. This gives smooth transitions from brake-on to brake-off, yielding fast, fluid loading cycles. The torque converter also has a standard lock-up clutch for fast, fuel efficient load and carry cycles.

- The Rimpull Control System has four factory preset reduced rimpull settings. Each setting corresponds to a maximum allowable impeller clutch pressure.
- Rimpull Control System allows the operator to vary rimpull based on operating conditions for maximum productivity while reducing tire slippage and resulting costs.
- Converter de-clutches during directional shifts. This allows full throttle directional shifts maintaining hydraulic speeds.
- Smooth approach to trucks and hoppers builds operator confidence, producing faster cycle times.
- Lock-up feature provides “direct drive” for load and carry applications. No converter slip means higher efficiency and lower fuel costs.
- Improved calibration procedure.
- Left pedal modulation.
- Compensates for wear.
- Provides the ability to recalibrate for optimum left pedal modulation regardless of torque converter wear.

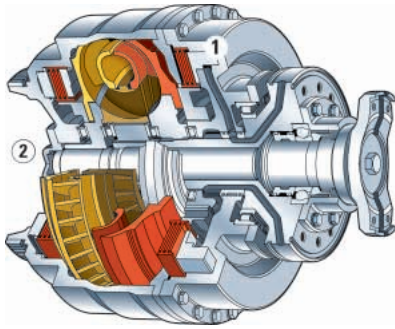

1 Impeller Clutch. Modulates the amount of engine power sent to the wheels.

2 Lock-Up Clutch. Provides direct drive for improved fuel economy. With Electronic Clutch Pressure Control, the impeller clutch torque converter with lock-up feature activates in second and third gears forward and first through third gears in reverse.

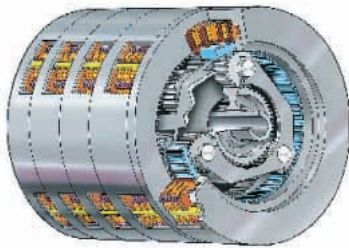

Planetary, Electronic, Power Shift Transmission. This is the same transmission found in the Cat 992G Wheel Loader. Electronic shifting provides smooth consistent shifts with fingertip controls housed in the STIC controller. Large diameter perimeter clutches coupled with high contact planetary gear sets provide high torque carrying capacity for long trouble-free life. Speed and direction controls are housed in the STIC controller.

Final Drives. Are planetary consisting of a ring gear, three planet gears or planet gear carrier and a sun gear. Features include:

- Ring gears splined to reaction hub
- Proprietary gear cutting and heat treat methods are used in manufacture of components
- Full-floating bronze sleeve bearings are used on planet gears
- Oil-bath lubrication of final drive

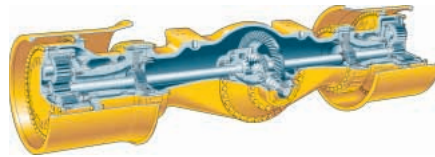

Axle-Shaft, Oil-Disc Brakes. Are fully hydraulic, completely sealed and never need adjustment. Disc face grooves provide cooling even when brakes are applied for a long, fade resistant life.

- This design provides a larger cooling oil reservoir and thicker separator plates than conventional brake designs. This gives the brake higher heat dissipation rates giving it higher capacity than conventional oil-disc brakes.
- The location of the brake reduces service time. Conventional brakes require final drive disassembly. The axle-shaft brake design allows brake service while leaving the final drive intact. Duo-cone® seals are between the wheel and spindle for a tight fit. Reduced service time (oil change interval is every 2,000 hours) and machine downtime keeps operating costs low.

Parking Brake. Is spring-applied, oil-released, dry disc that are mounted on the transmission transfer gear output shaft. The Electronic Monitoring System alerts the operator if the transmission is engaged while the parking brake is applied and also if the pressure drops and, in which case, the brake is automatically applied. Manual override is possible to allow movement of the machine.

Secondary Brakes. Are fully modulated and the front and rear service brake circuits are isolated, allowing one circuit to operate if pressure drops in the other.

Service Brakes. Are four wheel, hydraulic, oil dipped, multiple disc brakes that are adjustment-free, completely enclosed and allow modulated engagement without slack adjusters.

Starting System. Is direct-electric 24-volt with a 95-amp alternator and two 12-volt, 1,300 CCA, 190-amp-hour batteries.

Cooling System

Works with the engine to meet emissions standards as well as improve serviceability and reduce downtime.

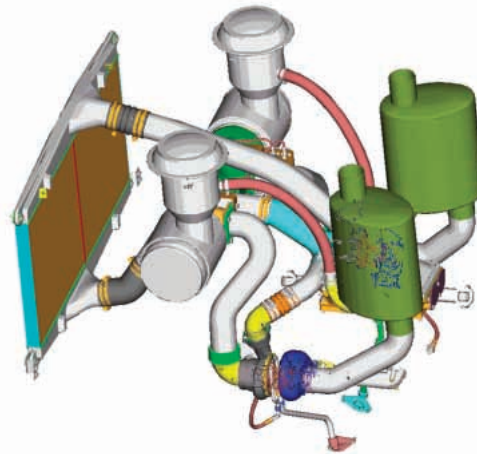
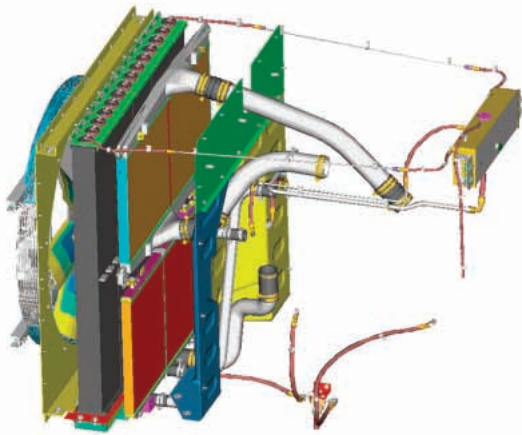

Next Generation Modular Radiator (NGMR) with Air-to-Air Aftercooling System (ATAAC). In order to meet U.S. EPA Tier 3 and EU Stage IIIa emissions requirements. The cooling system has been upgraded to a NGMR that utilizes the ATAAC system to achieve lower particulate, NO_x and sound output. The proven NGMR system is currently used on other Cat models such as the 834H, 844H, 988H and 992G. ATAAC technology became effective with the 834G and 988G.

NGMR is a Caterpillar® technology that improves serviceability and increases cooling efficiency by 22 percent. Ambient working temperature for the standard 990H is 43° Celsius (110° Fahrenheit). A high ambient cooling package, with a 50° Celsius (122° Fahrenheit) capacity, is available as an attachment.

ATAAC System. Provides a separate cooling system for the intake manifold air complementing the engine jacket water cooling system. The ATAAC system routes hot compressed air from the turbo and cools it with a single pass, air-to-air aluminum heat exchanger. The cooled compressed air is then delivered to the engine intake manifold. Providing the engine with cool compressed air greatly reduces the emissions produced, meeting Tier 3 requirements for a cleaner environment.

Separated Cooling System. The C27 engine with MEUI has a separated cooling system which isolates the NGMR and demand fan from the engine compartment. The cooling system is isolated from the engine compartment by a shield allowing the radiator to receive outside ambient air through the side and top vents at a much lower temperature than the hot air from the engine compartment. This improves the system's efficiency and allows the radiator size to be decreased and the rear hood to be sloped, improving the rear viewing area. Also, sound levels are reduced due to the lower fan speed of a more efficient cooling system.

Serviceability. Is a key feature of NGMR. Tubes are welded to a large, thick header, providing the strength of the tube-to-header joint that reduces the possibility of coolant leaks. The NGMR modular core design allows removal of a single core without removing the entire radiator – reducing downtime through ease of serviceability. Replacing the individual core also reduces repair costs.

Two-Pass System. Is a NGMR feature for increased cooling capacity. Coolant travels from the engine to the fan side of the bottom tank, up the fan side of each core, over the top, down the engine side of the core, into the engine side of the bottom tank and back to the engine. The improved flow pattern allows the coolant to pass through the radiator twice for better cooling. The NGMR design improves serviceability, reduces downtime and increases cooling capability.

Structures

Superior construction means superior strength.

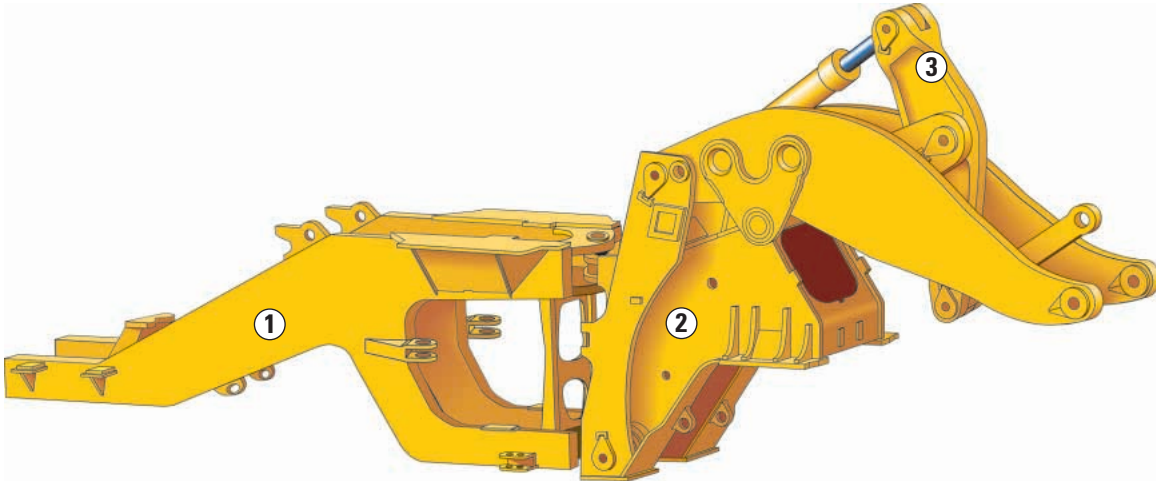

Structure Construction. Is more than 80 percent robotically welded. This provides highly consistent welds with deep plate penetration and excellent plate fusion. The benefit is greater fatigue strength and longer life than with conventional welding methods.

1 Box Section Rear Frame. Absorbs torsional forces generated in a loading cycle, maintaining alignment for hitch pins and driveline.

2 Four-Plate Loader Tower. Resists shock and torsional loads maintaining hitch and loader linkage pin alignment.

3 Design. Is for optimum strength. The 990H is equipped with a single-tilt Z-bar loader linkage with cast cross tube, cast tilt lever, solid plate lift arms, serviceable grease B-pin and center-point frame articulation.



4 Computer-Controlled Machining. At the top level allows structures to remain in their fixture throughout the machining process to ensure pin bore, axle pad and engine/transmission alignments.

Optional High Lift Linkage Configuration. Is available as a standard attachment. The High Lift configuration offers 565 mm (22.3 in) more dump clearance and 293 mm (11.5 in) additional reach at full lift and 45° dump. This gives the ability to load the 777 in six passes.

Buckets and Bucket Match

Cat buckets and Ground Engaging Tools provide the flexibility to match the machine. Proper bucket and application match delivers increased stability and peak performance.



Heavy-Duty Quarry

Heavy-Duty Quarry Bucket. Is available as an 8.6 m³ (11.2 yd³) capacity bucket and is recommended for use in face loading where moderate abrasion and high impact is encountered. It features additional wear protection items, including: thicker base edge and adapters, additional liners and wear plates, bolt-on half arrow segments and four sidebar protectors.

Buckets. For the 990H range in size from 8.4 m³ (11 yd³) to 9.2 m³ (12 yd³) and may be configured for a variety of impact and abrasive conditions. All buckets are built with shell-tine construction that resists twisting and distortion and feature replaceable, weld-on wear plates to protect the bottom of the bucket. The integral rock guard helps retain big loads while heavy-duty pins and retainers provide durability.



Spade Edge Rock

Rock Buckets. Are available in spade-edge or straight edge configurations. Spade edge buckets use bolt-on segments and are available from 8.4 m³ (11 yd³) to 9.2 m³ (12 yd³). An 8.6 m³ (12 yd³) Straight Edge Rock is also available. Each bucket accepts up to two sets of sidebar protectors, features double-strap adapters, easily changed bolt-on segments and several tip options.



High Abrasion

High Abrasion Bucket. Is available as an 8.6 m³ (11.2 yd³) capacity bucket and is recommended for use in face loading where high abrasion and moderate impact is encountered. This bucket features additional wear protection items including independently attached edge and adapter covers, flush mount adapters, additional liners and wear plates, four sidebar protectors (two sets) and a thicker base edge. Flush mount adapters provide a smooth finish floor and reduce wear on the adapters.

Buckets and Ground Engaging Tools (GET). The 990H offers a variety of bucket types and available GET configurations to properly configure the machine based on material density, impact and abrasion.

Depending on your material densities, there is a 8.4 m³ (11 yd³) Spade Nose bucket with teeth and bolt-on segments for improved performance and edge protection available.

Increased full turn static tip load, horsepower and hydraulic capabilities allow the 990H to effectively utilize the 8.6 m³ (11.25 yd³) and 9.2 m³ (12 yd³) bucket size in lighter materials such as limestone. All buckets feature the well proven shell-tine construction.

To better match your 990H to material conditions, contact your Caterpillar dealer for specialty bucket needs.

K-Series GET. Features reliable tip retention as the retainer locks securely to stabilize and tighten. Opposing inclined side rails on the adapter stabilize the tip, improve back loading resistance and reduce strain on the retainer. A tight fit between the tip and adapter limits movement and reduces wear. The adapter nose is stronger with no hole for the pin.

Tips.

	K130 (Replaces J550)	K150 (Replaces J600)
• General Duty	229-7129	229-7166
• Extra Duty	229-7121	229-7161
• Penetration	229-7122	229-7162
• Penetration Plus	229-7123	229-7163
• Heavy Penetration	229-7125	201-1240
• Heavy Abrasion	229-7126	201-1241

Custom Buckets. For specialty buckets and availability, contact your Caterpillar dealer.

Bucket Controls. Feature pilot-operated lift and tilt circuits for lower lever efforts.

Lift Circuit. Has four positions: raise, hold, lower and float and the automatic kickout from horizontal to full lift is adjustable.

Tilt Circuit. Features three positions: tilt back, hold and dump. The automatic bucket positioner can be adjusted to the desired loading angle and does not require visual spotting.

Bucket Selection Guide and Matrix

Rated payload 21.8 metric tons (24 tons)

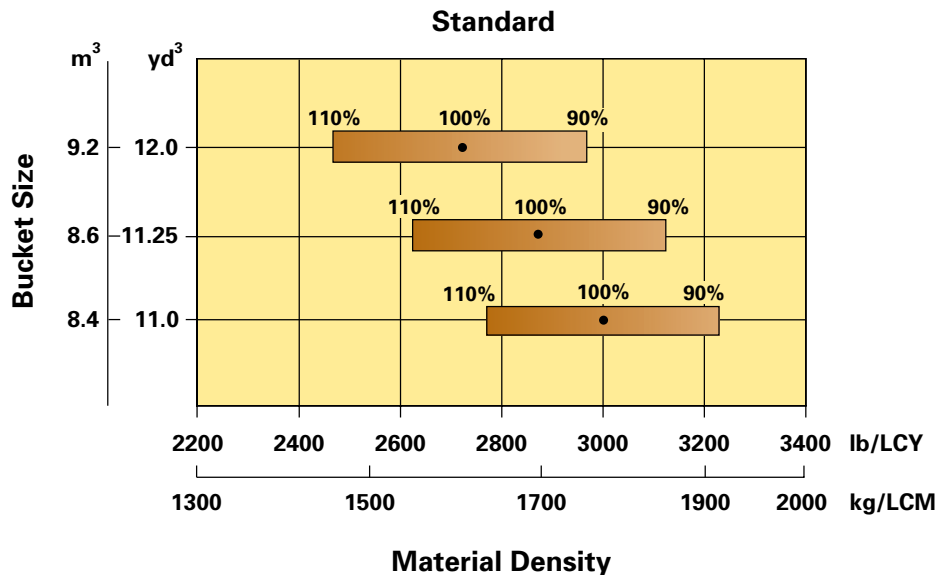

Changes in bucket weight, including field installed wear iron, can impact rated payload. Consult your Caterpillar dealer for assistance in selecting and configuring the proper bucket for the application. The Caterpillar Large Wheel Loader Payload Policy is a guideline intended to maximize wheel loader structural and component life.

Operator's Station

Comfort and control top quality operator's station will help maximize productivity.



Cab Design. Incorporates innovations for operator comfort and productivity include spaciousness, outstanding visibility, interior sound levels below 75 dB(A), a standard coat hook, cup holder, storage bin, tinted glass and intermittent wet-arm wipers. It is also radio-ready for two radios.

1 STIC™ Control System. Is a revolutionary system that integrates steering and transmission into a single controller. Simple side-to-side motions of the operator's left arm turn the machine right or left. Transmission shifting for forward, neutral, reverse is controlled by the operator's fingers and gear selection is controlled by the operator's thumb. These factors combine to produce a fluid motion that reduces effort and allows the operator to work the machine for long periods of time with little or no fatigue.

2 Left Pedal. Operates the impeller clutch torque converter for approximately the first inch of travel, then engages the brakes.

3 Comfort Series Seat. With air suspension and retractable seat belt, including (4) trainer seat and lapbelt, are designed for comfort and support. Seat cushions reduce pressure on the lower back and thighs while allowing unrestricted arm and leg movement. The seat has three height levels. The retractable seat belt stays off the floor and is easy to reach.

5 Floor-Mounted Hydraulic Controls. Are attached to the right side of the seat. They adjust fore and aft, with a height-adjustable armrest so operators of any size can find a comfortable operating position.

6 Electronic Monitoring System III (EMS III). Continually monitors various machine systems through three instrument clusters and provides a three-level warning system to alert the operator of immediate or pending problems. EMS III shares information with the engine, hydraulic and transmission controls that can be used during servicing to simplify service and troubleshooting.

7 Axle Temperature Sensor. Detects and warns the operator of extreme axle cooling oil temperature through indicator light.

8 Throttle Lock. Allows the operator to preset the engine speed for a variety of applications.

9 Rimpull Control System Switch. Turns the Rimpull Control System on and off.



10 Rimpull Control System (RCS). Device has four factory preset reduced rimpull settings. Each setting corresponds to a maximum allowable impeller clutch pressure and is user programmable. When in the reduced rimpull mode, the left brake pedal modulates rimpull from the reduced setting (pedal at rest position) to 20 percent of maximum. This gives the operator a quick way to return to the desired reduced rimpull setting and makes the entire first inch of pedal travel available for modulating the reduced rimpull.

11 Optional Payload Control System II. Offers on-the-go weighing to assist in loading trucks more accurately. It also has easy computer download capability.

Payload Control System II Monitor. Is used by the operator to keep track of Payload Control System II information.

12 Optional Ride Control System. Is used in roading, load and carry and other applications where load retention, spillage and operator ride may be a problem. It provides lift arm suspension system by placing an accumulator in the lift arm circuit.

Quick-Shift Feature. Allows quicker cycle times by shifting from 1st forward to 2nd reverse.

Bucket Controls. Feature pilot-operated lift and tilt circuits with a two lever controller that is floor-mounted and adjustable.

Lift Circuit. Has four positions: raise, hold, lower and float. It can adjust the automatic kickout from horizontal to full lift.

Tilt Circuit. Includes three positions: tilt back, hold and dump. The automatic bucket positioner can adjust to the desired loading angle and visual spotting is not required.

Hydraulic System

Powerful hydraulics are the invisible force behind the loader's muscle and flexibility.

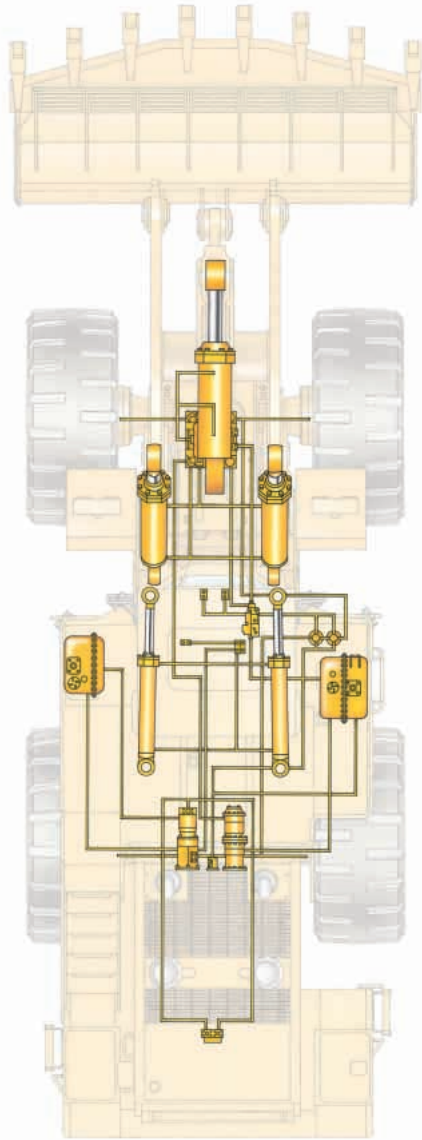

High Pressure Hydraulic System.

With main lift/tilt relief of 31 000 kPa (4,500 psi). Main lift/tilt controls are driven by fixed displacement piston pumps built by Caterpillar for optimum pressure was increased for better response. XT™-3 and XT™-6 hose is used on the entire machine except for the pilot lines and reusable coupling with o-ring face seals are reliable and reduce the risks of leaks.

Load-Sensing Steering System.

Maximizes engine power. Typical steering systems can draw more than 30 kW (40 hp) from the engine. The draw is constant even when the operator is not steering. The system maximizes performance by directing power through the steering system only when it is needed. For example, in hard digging, when the machine is not steering, all engine power is available to generate crowd, breakout and lift forces. More efficient use of power results in decreased fuel consumption and higher production.

Hydrostatic Cooling Fan. Is used for engine, transmission and hydraulic cooling. A variable displacement pump drives the fan's hydraulic motor so that fan speed varies with engine rpm. With the optional high ambient cooling package, the pump increases output as temperatures increase for greater cooling capability. The fan draws only the power needed for cooling, reducing fuel consumption and increasing efficiency.

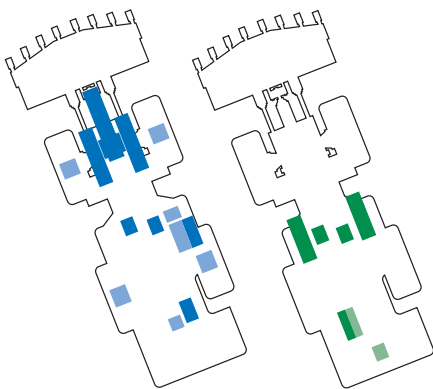

Two Separate Hydraulic Systems.

Improve the cooling and help prevent cross-contamination. One system is for lift/tilt and brakes, while the other is for the steering and engine cooling fan. If one system runs hot or is contaminated, the other will be unaffected.

Fast Cycle Times. With a high pressure system make the 990H remarkably productive. Just 9.2 seconds to raise, 2.9 seconds to dump and 3.8 seconds to lower.

Application Truck Match

Matched payloads and matched buckets ensure optimum performance.



Truck Match. The 990H is an aggressive first gear loader for face and bank excavation. With increased dump clearance, it can easily load 54 to 90 tonnes (60 to 100 ton) off-highway trucks. Increased performance and good pass match make the 990H a versatile performer with a cost per ton that will help your bottom line.

The versatility of a material handler is also designed into the machine. With balanced rimpull and hydraulics, the 990H is an aggressive loader that gets the job done quickly and efficiently in loose or stock-pile material and in load and carry work.

Large Wheel Loader/Truck Application Match

990H Rated Payload: Standard Arrangement = 15 metric tons (16.5 short tons)

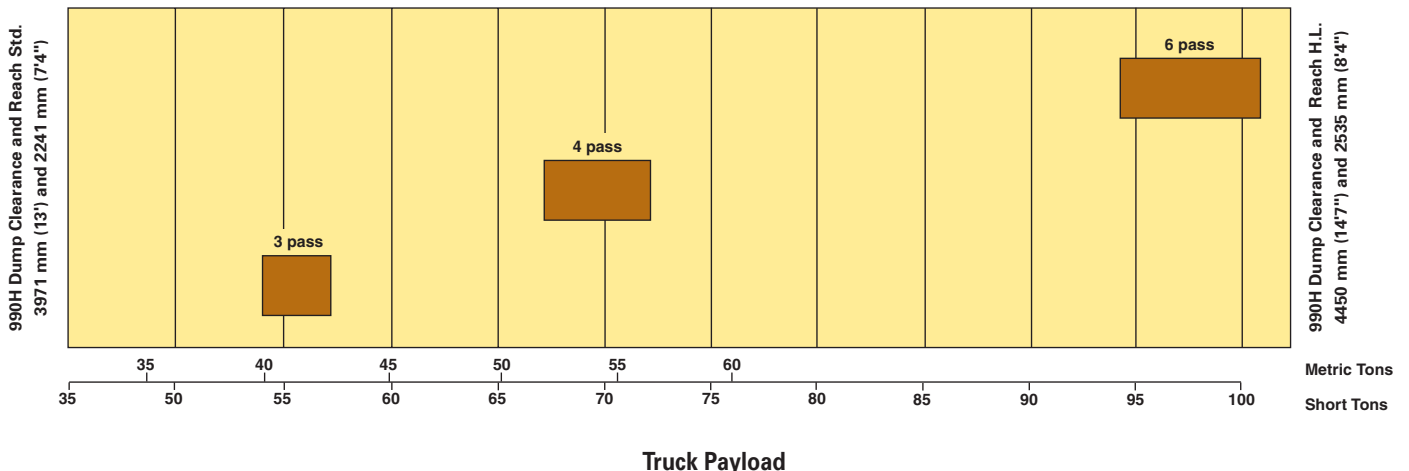

773E = 54 metric tons (60 short tons) nominal payload (3 pass)
 775E = 63 metric tons (70 short tons) nominal payload (4 pass)
 777D = 73 metric tons (100 short tons) nominal payload (6 pass)

High Lift Arrangement Optional Attachment

Offers high dump clearance and longer reach than the standard Cat 990H.

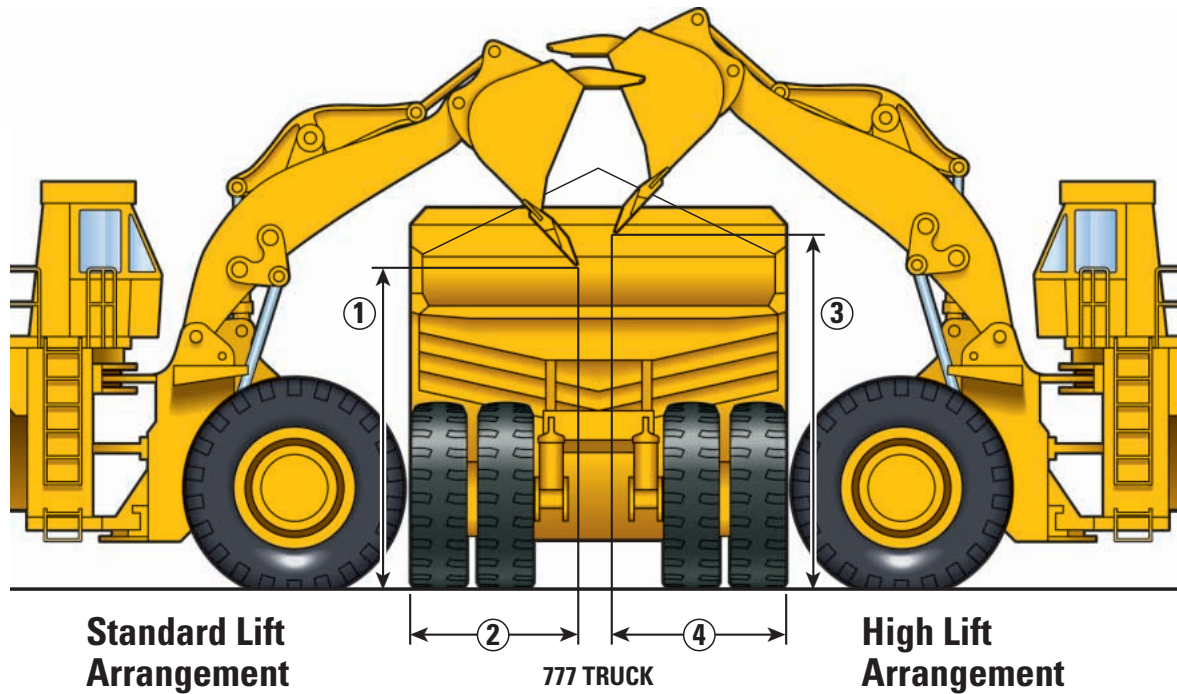

High Lift Arrangement. Provides up to 566 mm (22.3 in) more dump clearance at full lift and 45° discharge than the standard 990H, and 294 mm (11.5 in) more forward reach than the standard arrangement.

- Helps ensure heaped and centered loads for less haul road spillage and higher productivity.
- Loading time is reduced as a result of faster dump cycles due to better dump clearance and reach.

Truck Match. Designed for use with Cat 775 and 777 Off-Highway Trucks, either standard or equipped with sideboards. The 990H High Lift allows users to match larger trucks without the “larger loader” investment.

- 990H High Lift four passes the 775 and six passes the 777.
- High lift buckets are interchangeable with standard arrangement buckets.

Buckets. Achieve full capacity in aggregate and quarry applications with the 8.6 m³ (11.2 yd³). Buckets feature shell-tine construction with replaceable bolt-on wear plates, pin-on side protectors and integral rock guard.

1 Clearance at full lift and 45° dump, standard lift*

2 Reach at full lift and 45° dump, standard lift*

3 Dump clearance at full lift and 45° dump, high lift*

4 Reach at full lift and 45° dump, high lift*

* See charts on pages 21-22 for dimensions.

Serviceability

Easier maintenance and enhanced serviceability gives you more time in the pile.



Easier Maintenance and Repair.

Through monitoring key functions and logging critical indicators. Electronic diagnostic access is possible with a single tool, the Electronic Technician (Cat ET). In addition to the servicing features built into the engine, the 990H includes:

1 Daily Maintenance Checks. Most can be performed from the left side of the machine, making it part of an easy pre-start routine. Routine maintenance promotes long service life and durability.

2 Next Generation Modular Radiator.

Allows service technicians to replace individual cores for enhanced serviceability. Maintenance is also simplified since NGMR is isolated from the engine compartment.

3 Lube Points. Are centralized in accessible locations. Fuel fill is located on the left side. Both lube points and fuel fill are accessible from ground level, making lube and fuel service quicker and easier.

4 Swing-Out Doors. On both sides of the engine compartment provide easy access to the engine oil dipstick and filler spout, S•O•SSM port, fuel filters, air conditioner compressor, engine oil filters, alternator, starting receptacle, air filter service indicator, coolant fill and ether starting aid. The disconnect switch and diagnostic connector are located on the bumper next to the left side egress.

5 Hinged Doors. In the platform provide access to the hydraulic tank fill, lift/tilt and steering filters, transmission filler spout and dipstick.

6 Shock Resistant Lights. Are replaceable by hand, not requiring the use of any tools.

7 Batteries. Are accessible through hinged doors on the left-hand side of the bumper.

8 New Larger Fuel Tank. Provides 10 hours of production with a one-hour reserve.

9 Electronic Monitoring System III (EMS III). Provides operators and service technicians with diagnostic information on the machine's major components and systems.

• **Diagnostic Connector.** Enables quick evaluation of 11 starting and charging functions.

Complete Customer Support

Cat dealer services help you operate longer with lower costs.



Machine Selection. Make detailed comparisons of the machines under consideration before purchase. Cat dealers can estimate component life, preventative maintenance cost and the true cost of lost production.

Purchase. Look past initial price. Consider the financing options available as well as the day-to-day operating costs. Look at dealer services that can be included in the cost of the machine to yield lower equipment owning and operating costs over the long run.

Customer Support Agreements.

Cat dealers offer a variety of product support agreements and work with customers to develop a plan that best meets specific needs. These plans can cover the entire machine, including attachments, to help protect the customer's investment.

Product Support. You will find nearly all parts at our dealer parts counter. Cat dealers use a worldwide computer network to find in-stock parts to minimize machine downtime. Save money with genuine Cat Reman parts. You receive the same warranty and reliability as new products at cost savings of 40 to 70 percent.

Operation. Improving operating techniques can boost your profits. Your Cat dealer has training videotapes, literature and other ideas to help you increase productivity.

Maintenance Services. Choose from your dealer's range of maintenance services when you purchase your machine. Repair option programs guarantee the cost of repairs up front. Diagnostic programs such as S•O•SSM and Coolant Sampling and Technical Analysis help you avoid unscheduled repairs.

Replacement. Repair, rebuild or replace? Your Cat dealer can help you evaluate the cost involved so you can make the right choice.

Engine

Engine Model	Cat C27 ACERT™	
Gross Power	512 kW	687 hp
Net Power	468 kW	627 hp
Net Power – Caterpillar	468 kW	627 hp
Net Power – EEC 80/1269	468 kW	627 hp
Net Power – ISO 9249	468 kW	627 hp
Net Power – SAE J1349	463 kW	621 hp
Net Power – DIN 70020	650 PS	
Bore	137 mm	5.4 in
Stroke	152 mm	6 in
Displacement	27.1 L	1,666 in ³

- These ratings apply at 2,000 rpm when tested under the specified standard conditions for the specified standard.
- Power rating conditions are based on standard air conditions of 25° C (77° F) and 99 kPa (29.32 in Hg) dry barometer, used 35° API gravity fuel having an LHV of 42 780 kJ/kg (18,390 Btu/lb) when used at 30° C (86° F) [ref. a fuel density of 838.9 g/L (7.001 lb/gal)].
- Net power advertised is the power available at the flywheel when the engine is equipped with fan, air cleaner, muffler and alternator.
- No derating required up to 3300 m (11,000 ft) altitude.

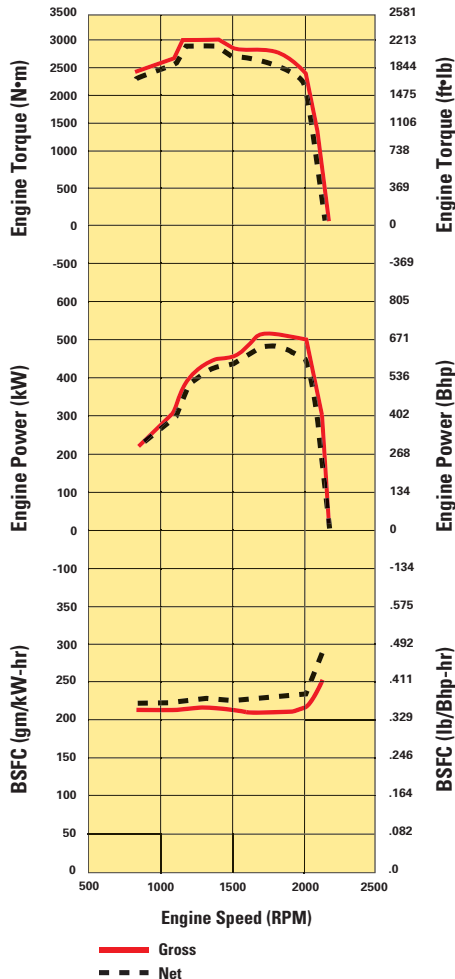

Operating Specifications

Rated Payload	15 tonnes	16.5 tons
Operating Weight	77 842 kg	171,642 lb
Bucket Capacity Range	8.4-9.2 m ³	11-12 yd ³
Static Tipping Load, Full Turn	38 243 kg	84,311 lb
Static Tipping Load, Full Turn – HL	39 048 kg	86,085 lb
Dump Clearance	3952 mm	13 ft
Breakout Force	583.6 kN	131,194 lb
Operating Weight – HL	83 252 kg	183,539 lb
Breakout Force – HL	536 kN	120,498 lb
Articulation Angle	35°	

Transmission

Transmission Type	Powershift	
Forward 1	7 km/h	4.35 mph
Forward 2	12.8 km/h	7.95 mph
Forward 3	22.4 km/h	13.92 mph
Reverse 1	7.9 km/h	4.91 mph
Reverse 2	14.1 km/h	8.76 mph
Reverse 3	24.8 km/h	15.41 mph
Converter Drive – Forward 1	7 km/h	4.3 mph
Converter Drive – Forward 2	12.1 km/h	7.5 mph
Converter Drive – Forward 3	20.8 km/h	12.9 mph
Converter Drive – Reverse 1	7.7 km/h	4.8 mph
Converter Drive – Reverse 2	13.4 km/h	8.3 mph
Converter Drive – Reverse 3	22.8 km/h	14.2 mph
Direct Drive – Forward 1	Lock-up disabled	
Direct Drive – Forward 2	12.8 km/h	7.9 mph
Direct Drive – Forward 3	22.4 km/h	13.9 mph
Direct Drive – Reverse 1	7.9 km/h	4.9 mph
Direct Drive – Reverse 2	14.1 km/h	8.8 mph
Direct Drive – Reverse 3	24.8 km/h	15.4 mph

Hydraulic System – Lift/Tilt

Number of Lift Cylinders	2
Number of Tilt Cylinders	1

Hydraulic Cycle Time

Raise	9.2 Seconds
Dump	2.9 Seconds
Lower Float Down (Empty)	3.8 Seconds
Total Hydraulic Cycle Time	15.9 Seconds

Service Refill Capacities

Fuel Tank	1074 L	284 gal
Cooling System	190 L	50.2 gal
Crankcase	95 L	25 gal
Transmission	110 L	29 gal
Differentials and Final Drives – Front	271 L	71.6 gal
Differentials and Final Drives – Rear	261 L	68.9 gal
Hydraulic System (tank only)	174 L	45.97 gal
Hydraulic System – Lift/Tilt and Brakes	435 L	113 gal
Hydraulic System – Steering and Engine Cooling Fan	194 L	50.5 gal
Hydraulic System (including tank)	435 L	114.91 gal

Dimensions

Height to Top of Exhaust Stacks	4726 mm	15 ft 7 in
Height to Top of ROPS/FOPS	5070 mm	16 ft 8 in
Ground Clearance	478 mm	1 ft 8 in
Reach at Max. Lift/Dump – Std	1799 mm	5 ft 11 in
Reach at Max. Lift/Dump – HL	2540 mm	8 ft 4 in
Clearance at Max. Lift/Dump – Std	4135 mm	13 ft 9 in
Clearance at Max. Lift/Dump – HL	4518 mm	14 ft 10 in
Wheel Base Length	4600 mm	15 ft 2 in
Overall Length – Std	12 839 mm	42 ft 2 in
Overall Length – HL	13 578 mm	44 ft 8 in
Width Over Tires	4071 mm	13 ft 4 in
Turning Circle – Std	20 740 mm	68 ft 2 in
Full Turn Static Tipping Load at 35°	38 243 kg	84,311 lb
Turning Circle – HL	21 514 mm	70 ft 8 in
Straight Static Tipping Load – Std	43 392 kg	93,457 lb
Straight Static Tipping Load – HL	44 152 kg	97,338 lb
Hinge Pin Height at Full Lift – Std	5866 mm	19 ft 3 in
Hinge Pin Height at Full Lift – HL	6432 mm	21 ft 2 in
Tread Width	3050 mm	10 ft

- 990H dimensions based on 9.2 m³ (12 yd³) bucket with teeth and segments

Buckets

Bucket Capacities	8.4-9.2 m ³ (11-12 yd ³)
-------------------	---

Axles

Maximum Single-Wheel Rise and Fall	572 mm	22.5 in
Front	Fixed	
Rear	Oscillating	
Oscillation Angle	±11°	

Brakes

Brakes	Meet SAE/ISO 3450 1996
--------	------------------------

Cab

Cab – ROPS/FOPS	Meets SAE and ISO standards
Sound Performance	Meets ANSI, SAE and ISO standards

- Cat cab Rollover Protective Structure (ROPS/FOPS) are standard.
- Standard air conditioning system contains environmentally friendly R134a refrigerant.
- ROPS meets SAE J1040 APR88 and ISO 3471:1994 criteria.
- FOPS meets SAE J231 JAN81 and ISO 3449:1992 Level II criteria.
- The operator sound exposure Leq (equivalent sound pressure level) measured according to the work cycle procedures specified in ANSI/SAE J1166 OCT98 is 72 dB(A), for the cab offered by Caterpillar, when properly installed, maintained and tested with the doors and windows closed.
- Hearing protection may be needed when operating with an open operator station and cab (when not properly maintained or doors/windows open) for extended periods or in noisy environment.
- The exterior sound pressure level for the standard machine measured at a distance of 15 m (49.2 ft) according to the test procedures specified in SAE J88 JUN86 mid-gear-moving operation is 82 dB(A).
- The sound power level is 116 dB(A) measured according to the dynamic test procedure and conditions specified in ISO 6395:1988/Amd. 1:1996 for a standard machine configuration.
- For “CE” marked configurations, the labeled sound power level is 114 dB(A) measured according to the test procedures and conditions specified 2000/14/EC.

Steering

Minimum Turning Radius (over bucket)	10 337 mm	407 in
Steering Angle, each direction	35°	
Hydraulic Output at 2,128 rpm and 6900 kPa (1,000 psi)	410 L/min	108 gal/min
Relief Valve Setting	31 000 kPa	4,500 psi
Minimum Turning Radius (over bucket) – HL	10 757 mm	424 in

Tires

Tires	Tires used for measurement – 41.25/70-39 42 ply
-------	---

- 41.25/70-39 42PR L5 General
- 41.25/70-39 42 PR L5 Firestone
- 45/65 R39 L5 VSDL Bridgestone*
- 45/65 R39 XLDD2 L5 Michelin*
- Note: In certain applications (such as load and carry), the loader's productive capabilities might exceed the tires' tonnes-km/h (ton-mph) capabilities. Caterpillar recommends that you consult a tire supplier to evaluate all conditions before selecting a tire model. Other special tires are available on request.

Loader Hydraulic System

Main Hydraulic System Output at 2,128 rpm and 6900 kPa (1,000 psi)	650 L/min	172 gal/min
Relief Valve Setting	31 000 kPa	4,500 psi
Cylinders, Double Acting: Lift, Bore and Stroke	234 mm × 1270 mm	9.25 in × 50 in
Cylinder, Double Acting: Tilt, Bore and Stroke	292 mm × 820 mm	11.5 in × 32.3 in
Pilot System, Gear-Type Pump Output at 2,000 rpm and 6900 kPa (1,000 psi)	46 L/min	12 gal/min
Relief Valve Setting (low idle)	2400 kPa	350 psi

Dimensions

All dimensions are approximate.

- ◆ Dimensions vary with bucket. Refer to operating specifications chart on pages 21-22.

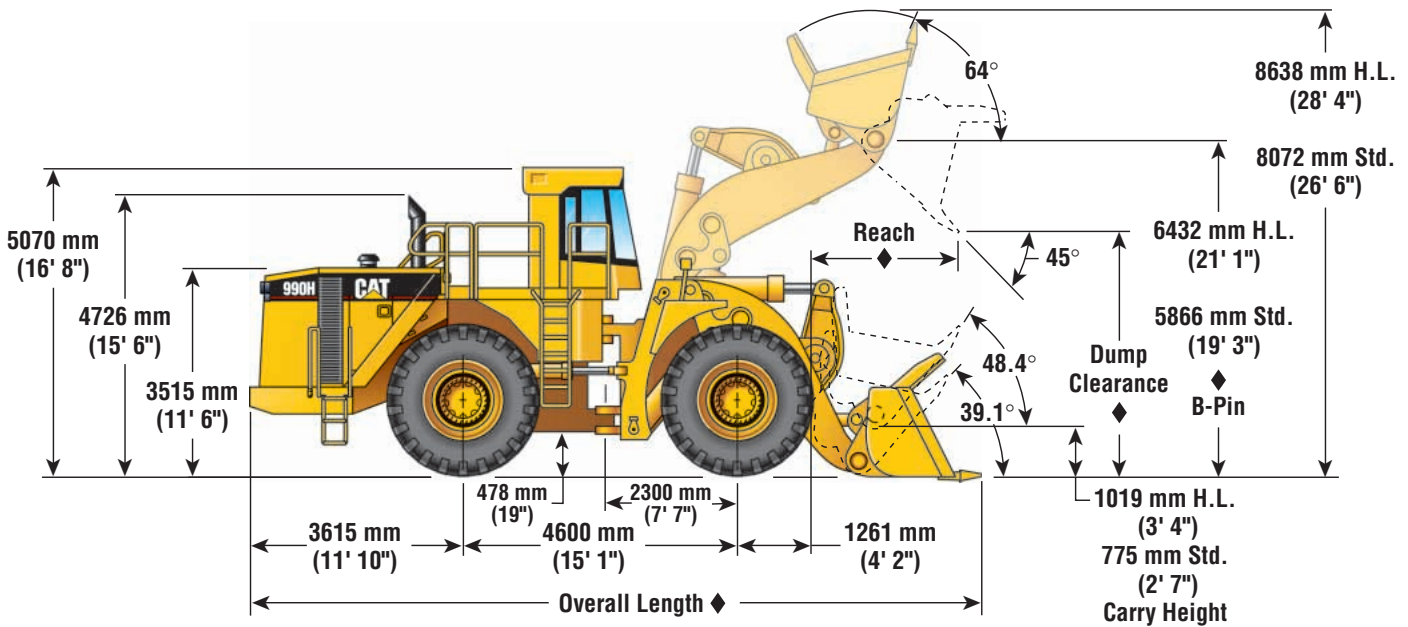

Supplemental Specifications

	Width over tires		Ground clearance		Change in vertical dimensions		Change in operating weight		Change in full turn static tipping load	
	mm	inches	mm	inches	mm	inches	kg	lb	kg	lb
41.25/70-39 42 PR (L-5) General	4183	164.7	478	18.8	—	—	—	—	—	—
41.25/70-39 42 PR (L-5) Firestone	4211	165.8	475	18.7	3	0.1	368	812	214	471
54/65R39 (L-5) Bridgestone	4303	169.4	458	18.0	20	0.8	464	1024	269	594
45/65R39 (L-5) Michelin XLDD2A	4369	172.0	427	16.8	51	2	229	504	133	292

Operation Specifications: Standard Lift

Bucket Type	Standard Lift					
		Spade BOCE	Spade HDLT & BOS	Spade HDTL & BOS	High Abrasion	HD Quarry
Rated Capacity	m ³	8.6	8.6	9.2	8.6	8.6
	yd ³	11.25	11.25	12.0	11.25	11.25
Struck Capacity	m ³	7.3	7.3	7.8	7.3	7.3
	yd ³	9.5	9.5	10.2	9.5	9.5
Bucket Width	mm	4450	4450	4610	4574	4450
	ft-in	14'7"	14'7"	15'2"	15'0"	14'7"
Clearance at Full Lift, 45° Dump SAE	mm	4192	4172	4116	4215	4171
	ft-in	13'9"	13'8"	13'6"	13'10"	13'8"
	Tooth tip mm	N/A	3971	3918	3957	3921
	ft-in	N/A	13'0"	12'10"	13'0"	12'10"
Reach at Full Lift, 45° Dump SAE	mm	1740	1620	1661	1708	1622
	ft-in	5'9"	5'9"	5'5"	5'7"	5'4"
	Tooth tip mm	N/A	2241	2294	2280	2272
	ft-in	N/A	7'4"	7'6"	7'6"	7'5"
Reach @ Level Arm and Level Bucket SAE	mm	3516	3367	3426	3492	3370
	ft-in	11'7"	11'6"	11'3"	11'6"	11'1"
	Tooth tip mm	N/A	4256	4331	4331	4313
	ft-in	N/A	14'0"	14'3"	14'3"	14'2"
Digging Depth	mm	148	168	168	168	168
	inch	7"	6.6"	6.6"	6.6"	6.6"
Overall Length Edge	mm	12 527	12 555	12 905	12 495	12 557
	ft-in	41'1"	41'2"	42'4"	41'0"	41'2"
	Tooth tip mm	N/A	12 830	12 635	12 867	12 887
		ft-in	N/A	42'1"	41'5"	42'3"
Overall Height with Loaded Bucket at Max. Lift and Racked	mm	8072	8072	8072	8072	8072
	ft-in	26'6"	26'7"	26'6"	26'6"	26'6"
Clearance Circle @ Carry Edge	mm	20 564	20 507	20 684	20 683	20 509
	ft-in	67'6"	67'3"	67'10"	67'10"	67'3"
	Tooth tip mm	N/A	20 684	20 857	20 816	20 740
		ft-in	N/A	67'10"	68'5"	68'4"
Tipping Load (at operating weight) Str	kg	46 962	46 453	45 923	44 184	45 285
	lb	103,551	102,428	101,260	97,426	101,891
	35° art kg	42 021	41 515	41 105	39 263	40 345
		lb	92,656	91,541	90,637	86,575
Breakout Force	kN	602	594	569	603	589
	lb	135,429	133,650	128,025	135,675	132,525
Operating Weight†	kg	77 500	77 842	78 127	79 692	78 922
	lb	170,888	171,642	172,270	175,721	177,575

* DST and BOS = Double Strap Teeth and Bolt-On Segments, BOCE = Bolt-On Cutting Edge.

** Dimensions measured to end of teeth and do not conform to SAE standard.

† Static tipping load and operating weight are based on standard machine configuration with 41.25/70-39 42 PR (L-5) tires, full fuel lubricants and operator.

†† Measured 102 mm (4 in) behind tip of cutting edge with bucket hinge pin as pivot point in accordance with SAE J732c.

NOTE: Specifications and ratings conform to all applicable standards recommended by the Society of Automotive Engineers. SAE Standard J732 JUN92 and J742 FEB85 govern loader ratings, denoted in the text by (§).

Operation Specifications: High Lift

		High Lift				
Bucket Type		Spade BOCE	Spade HDLT & BOS	High Abrasion	HD Quarry	
Heaped Capacity	m ³	8.6	8.6	8.6	8.6	
	yd ³	11.25	11.25	11.25	11.25	
Struck Capacity	m ³	7.3	7.3	7.3	7.3	
	yd ³	9.5	9.5	9.5	9.5	
Bucket Width	mm	4450	4450	4574	4450	
	ft-in	14'7"	14'7"	15'0"	14'7"	
Clearance at Full Lift, 45° Dump SAE	mm	4761	4738	4780	4737	
	ft-in	15'7"	15'7"	15'8"	15'7"	
	mm	N/A	4536	4523	4487	
	ft-in	N/A	14'11"	14'10"	14'9"	
Reach at Full Lift, 45° Dump SAE	mm	2033	1914	2002	1916	
	ft-in	6'8"	6'3"	6'7"	6'3"	
	mm	N/A	2535	2574	2566	
	ft-in	N/A	8'4"	8'5"	8'5"	
Reach @ Level Arm and Level Bucket SAE	mm	4116	3967	4092	3970	
	ft-in	13'6"	13'0"	13'5"	13'0"	
	mm	N/A	4856	4893	4913	
	ft-in	N/A	15'11"	16'1"	16'1"	
Digging Depth - Bucket Level	mm	190	210	210	210	
	inch	7.5"	8"	8"	8"	
Overall Length	Edge	mm	13 260	13 286	13 226	13 288
		ft-in	43'6"	43'7"	43'5"	43'7"
	Tooth tip	mm	N/A	13 561	13 598	13 618
		ft-in	N/A	44'6"	44'7"	44'8"
Overall Height with Loaded Bucket at Max. Lift and Racked	mm	8638	8638	8638	8638	
	ft-in	28'4"	28'4"	28'4"	28'4"	
Clearance Circle @ Carry	Edge	mm	21 189	21 123	21 305	21 124
		ft-in	69'6"	69'4"	69'11"	69'4"
	Tooth tip	mm	N/A	21 338	21 481	21 398
		ft-in	N/A	70'0"	70'6"	70'2"
Tipping Load (at operating weight)	Str	kg	43 349	42 866	40 674	41 720
		lb	95,585	94,520	89,686	91,993
	35° art	kg	38 436	37 956	35 779	36 807
		lb	84,751	83,693	78,893	81,159
Breakout Force	kN	568	561	568	556	
	lb	127,800	126,225	127,800	125,100	
Operating Weight†	kg	81 597	81 939	83 789	83 019	
	lb	179,881	180,676	184,755	183,057	

* DST and BOS = Double Strap Teeth and Bolt-On Segments, BOCE = Bolt-On Cutting Edge.

** Dimensions measured to end of teeth and do not conform to SAE standard.

† Static tipping load and operating weight are based on standard machine configuration with 41.25/70-39 42 PR (L-5) tires, full fuel lubricants and operator.

†† Measured 102 mm (4 in) behind tip of cutting edge with bucket hinge pin as pivot point in accordance with SAE J732c.

NOTE: Specifications and ratings conform to all applicable standards recommended by the Society of Automotive Engineers. SAE Standard J732 JUN92 and J742 FEB85 govern loader ratings, denoted in the text by (§).

Standard Equipment

Standard equipment may vary. Consult your Caterpillar dealer for details.

Electrical

- Alarm, back-up
- Alternator (95-amp)
- Batteries, maintenance-free
- Deutsch terminal connectors
- Diagnostic connector starting and charging system
- Electrical system, 24-volt
- Electronic transmission control
- Lighting system, halogen
 - (front and rear) working, plus stop lights

- Starter, electric
- Starter receptacle for emergency start

Operator Environment

- Air conditioner
- Cab, sound-suppressed rollover protective structure (ROPS/FOPS)
 - Radio ready for (entertainment) includes antenna, speakers and converter (12-volt 5-amp)

- Cigar lighter and ashtray

- Coat hook

- Computerized monitoring system (EMS II)

- Instrumentation, gauges:

- Coolant temperature
 - Fuel level
 - Hydraulic oil temperature
 - Tachometer
 - Transmission oil temperature

- Instrumentation, warning indicators:

- Axle oil temperature (front and rear)
 - Brake oil pressure
 - Brake, parking/secondary
 - Electrical system (low voltage)
 - Engine oil pressure
 - Engine coolant flow
 - Engine overspeed
 - Secondary steering (if so equipped)
 - Steering oil temperature
 - Transmission filter status

- Heater and defroster

- Horn, electric

- Indicator lights:

- Quick-shift, throttle lock, torque converter and reduced rimpull control

- Lift and tilt function lockout

- Light, dome (cab)

- Lunchbox and beverage holders

- Mirrors, rearview (exterior mounted)

- Quick shift feature

- Seat belt, retractable, 76 mm (3 in) wide

- Seat, Cat Comfort, (cloth) air suspension

- STIC control system

- Tinted glass

- Wet-arm wiper/washers (front, rear, and corner)

- Intermittent front wiper

Power Train

- Brakes, full hydraulic, enclosed, oil-disc

- Axle-shaft oil-disc service brake, parking/secondary brake

- Demand fan

- Engine, Cat C27 ACERT™ with MEUI fuel system, ATAAC and ECM

- Fuel priming pump

- Precleaner, engine air intake

- Radiator, Next Generation Modular

- Separated cooling system

- Starting aid (ether) manual override

- Throttle lock

- Torque converter, impeller clutch with lock-up clutch feature and rimpull control system

- Transmission, 533 mm (21 in) planetary power shift (electronic) (3F/3R)

Other Standard Equipment

- Automatic bucket leveler

- Automatic lift kickout

- Axle temperature sensor

- Engine, crankcase, 500 hour interval with Cat approved oil

- Fenders, steel (front)

- Grouped labeled lube points

- Guards, crankcase and power train

- Hood, tapered

- Hitch, drawbar with pin

- Mufflers (under hood)

- Oil sampling valves

- Sight gauges for steering/fan and implement/brake

- Stairway, left side rear access

- Steering, load sensing

- Step for front windshield cleaning

- Vandalism protection caplocks

- Venturi stack

Tires, Rims and Wheels

- A tire must be selected from the mandatory attachments section. Base machine price includes a tire allowance.

Antifreeze

- Premixed 50% concentration of extended life coolant with freeze protection to -34° C (-29° F)

Optional Equipment

With approximate changes in operating weights.

	kg	lb		kg	lb
Buckets	See Buckets		Oil change system		
Bucket attachments:			Auto Lube	5	11
Bucket teeth, long (set of 8)	145	320	Payload control system II	32	70
Bucket teeth, short (set of 8)	145	320	Precleaner, Cab	2	5
Bucket teeth, HD long (set of 8)	190	418	Ride Control System	180	396
Side bar protectors (set of 2)	45	100	Sound Suppression/Spectator	173	382
Camera, Rear Vision	5	12	Stairway		
Filtration, Case Drain	43	94	Left/Right with Roding Fenders	417	920
Fuel system – Fast Fill meets	1	3	Right Hand	195	430
EUI Pressure Vessel Requirements			Starting aids		
High Ambient Cooling Arrangement	12	26.5	Cold weather starting system	180	396
High Lift Arrangement	1136	2504	Diesel fuel heater	7	15
Lights			Heater, engine coolant	4	8
Engine Compartment	0	0	Supplemental steering	71	157
HID	27	59	Tires	See specifications	
Warning Beacon	0	0			

Notes

Notes

990H Wheel Loader

For more complete information on Cat products, dealer services,
and industry solutions, visit us on the web at www.cat.com

© 2005 Caterpillar
All Rights Reserved
Printed in U.S.A.

Materials and specifications are subject to change without notice.
Featured machines in photos may include additional equipment.
See your Caterpillar dealer for available options.

AEHQ5688 (11-05)

Replaces AEHQ3827-06

CAT, CATERPILLAR, ACERT, their respective logos and "Caterpillar Yellow,"
as well as corporate and product identity used herein, are trademarks of
Caterpillar and may not be used without permission.

CATERPILLAR[®]